

Contents	I
Preface	III
Scientific Committee	IV
Fundamental Constants, Equations and Useful Formulas	V
Theoretical Problems	
Problem 1 Separation and Identification of Ions	1
Problem 2 Preparation and Applications of Radioisotopes	2
Problem 3 Ion Exchangers	3
Problem 4 Determination of Calcium Ion by Precipitation Followed by Redox Titration	7
Problem 5 Nitrogen in Wastewater	8
Problem 6 Use of Isotopes in Mass Spectrometry	10
Problem 7 Atomic Orbitals	11
Problem 8 Intermolecular Forces	11
Problem 9 Crystal Packing	13
Problem 10 Applications of Transition Metals	14
Problem 11 Electrochemistry of Inorganic Compounds	15
Problem 12 Metal Carbonyl Compounds	16
Problem 13 Carbocation and Aromaticity	18
Problem 14 Photochemical Ring Closure and Opening	19
Problem 15 Stereochemistry	21
Problem 16 Organic Synthesis	24
Problem 17 Spectroscopy and Polymer Chemistry	26
Problem 18 Crown Ether and Molecular Recognition	30
Problem 19 Enzyme Catalysis	32
Problem 20 Work in Thermodynamics	33
Problem 21 Kinetics — Atmospheric Chemistry	33
Problem 22 Kinetics and Thermodynamics	33
Problem 23 Phase Diagram	34
Problem 24 Standard Deviation in One-Dimensional Quantum Mechanics	35
Problem 25 A Particle in a 2-D Box Quantum Mechanics	36
Problem 26 Spectral Analyzer	37
Problem 27 Time-of-Flight Mass Spectrometer	39
Practical Problems	
Safety Rules	41
Problem 28 Identification of Unknown Solid Samples	47
Problem 29 Identification of Unknown Solutions (I) – Spot Test without Electrolysis	48
Problem 30 Identification of Unknown Solutions (II) – Spot Test with Electrolysis	49
Problem 31 Quantitative Analysis of Ascorbic Acid in a Vitamin C Tablet	50
Problem 32 Determination of an Equilibrium Constant	53
Problem 33 Preparation of Acetylsalicylic Acid	55
Problem 34 Analysis of Aspirin Tablets	57
Problem 35 Resolution of (\pm)- α -Methylbenzylamine and Determination of the Optical Purity	58
Answers to Problems	
Answer 1 Separation and Identification of Ions	61
Answer 2 Preparation and Applications of Radioisotopes	64
Answer 3 Ion Exchangers	65
Answer 4 Determination of Calcium Ion by Precipitation Followed by Redox Titration	66
Answer 5 Nitrogen in Wastewater	68
Answer 6 Use of Isotopes in Mass Spectrometry	68

Answer 7	Atomic Orbitals	69
Answer 8	Intermolecular Forces	69
Answer 9	Crystal Packing	71
Answer 10	Applications of Transition Metals	71
Answer 11	Electrochemistry of Inorganic Compounds	72
Answer 12	Metal Carbonyl Compounds	73
Answer 13	Carbocation and Aromaticity	75
Answer 14	Photochemical Ring Closure and Opening	75
Answer 15	Stereochemistry	76
Answer 16	Organic Synthesis	77
Answer 17	Spectroscopy and Polymer Chemistry	78
Answer 18	Crown Ether and Molecular Recognition	79
Answer 19	Enzyme Catalysis	79
Answer 20	Work in Thermodynamics	81
Answer 21	Kinetics — Atmospheric Chemistry	82
Answer 22	Kinetics and Thermodynamics	82
Answer 23	Phase Diagram	83
Answer 24	Standard Deviation in One-Dimensional Quantum Mechanics	84
Answer 25	A Particle in a 2-D Box Quantum Mechanics	85
Answer 26	Spectral Analyzer	85
Answer 27	Time-of-Flight Mass Spectrometer	85
Appendix I: Minutes of the Steering Committee Meeting		86
Appendix II: Information for Mentors at the International Chemistry Olympiad		90
Appendix III: International Chemistry Olympiad Appendix C (updated 2004)-Syllabus		100

Preface

This booklet contains preparatory problems and “Information for Mentors at the International Chemistry Olympiad” approved by the Taipei Dec. 2-5 2004 Steering Committee Meeting for the 37th International Chemistry Olympiad in 2005. According to the Syllabus of the IChO, the problems were designed to emphasize the discovery and trend of the global chemistry field, and to highlight the unique chemical researches in Taiwan including natural resources, medicines, energy, materials and environment.

In spite of proof reading efforts, you will probably find some mistakes, and we will highly appreciate your critical remarks and constructive comments.

Finally, we hope that the students will benefit from this booklet as they prepare for the competition in the 37th 2005 IChO. Welcome to Formosa – Taiwan and welcome to Taipei! Good luck!

Prof. Tai-Shan Fang, Ph.D.
Secretariat, 37th 2005 IChO
Department of Chemistry
National Taiwan Normal University
88 Sec. 4, Ting-Chou Road Taipei, Taiwan 116
Tel: +886-2-29350749 ext. 423
Mobile: +886-921882061
Tel & Fax: +886-2-29309074 / +886-2-29307327
E-mail: 2005icho@sec.ntnu.edu.tw
<http://icho.chem.ntnu.edu.tw>

37th International Chemistry Olympiad

Taipei, Taiwan
July 16 - 25, 2005

Scientific Committee

President: Dr. Chan, Sunney I. Academia Sinica
Coordination: Dr. Peng, Shie-Ming National Taiwan University
Manager: Dr. Fang, Tai-Shan National Taiwan Normal University
Secretary: Dr. Chang, I-Jy National Taiwan Normal University

Theoretical Section

Dr. Fang, Jim-Min National Taiwan University
Dr. Her, Guor-Rong National Taiwan University
Dr. Jin, Bih-Yaw National Taiwan University
Dr. Leung, Man-Kit National Taiwan University
Dr. Lin, Cheng-Huang National Taiwan Normal University
Dr. Lin, King-Chuen National Taiwan University
Dr. Lin, Sheng-Hsien Academia Sinica
Dr. Lin, Ying-Chih National Taiwan University
Dr. Lu, Kuang-Lieh Academia Sinica
Dr. Peng, Shie-Ming National Taiwan University
Dr. Shih, Jeng-Shong National Taiwan Normal University
Dr. Whang, Chen-Wen Tunghai University
Dr. Wong, Ken-Tsung National Taiwan University

Practical Section

Dr. Chang, I-Jy National Taiwan Normal University
Dr. Chen, Chien-Tien National Taiwan Normal University
Dr. Chen, Kwunmin National Taiwan Normal University
Dr. Fang, Tai-Shan National Taiwan Normal University
Dr. Horng, Jhy-Ming National Taiwan Normal University
Dr. Shiau, George T. College Entrance Examination Center
Dr. Yao, Ching-Fa National Taiwan Normal University
Dr. Yeh, Ming-Chang P. National Taiwan Normal University
Dr. Mou, Chung-Yuan National Taiwan University
Dr. Shieh, Ming-Huey National Taiwan Normal University
Lecturer She, Jui-Lin National Taiwan University

Fundamental Constants, Equations and Conversion Factors

Atomic mass unit	$1 \text{ amu} = 1.6605 \times 10^{-27} \text{ kg}$
Avogadro's number	$N = 6.02 \times 10^{23} \text{ mol}^{-1}$
Boltzmann's constant	$k = 1.38065 \times 10^{-23} \text{ J K}^{-1}$
Electron charge	$e = 1.6022 \times 10^{-19} \text{ C}$
Faraday's constant	$F = 9.6485 \times 10^4 \text{ C mol}^{-1}$
Mass of electron	$m_e = 9.11 \times 10^{-31} \text{ kg}$
Mass of neutron	$m_n = 1.67492716 \times 10^{-27} \text{ kg}$
Mass of proton	$m_p = 1.67262158 \times 10^{-27} \text{ kg}$
Planck's constant	$h = 6.63 \times 10^{-34} \text{ J s}$
Speed of light	$c = 3 \times 10^8 \text{ m s}^{-1}$
Nernst equation (T = 298 K)	$E = E^\circ - (0.0592 / n) \log K$

Clausius-Clapeyron equation	$\ln P = -\Delta H_{vap} / RT + B$
Ideal gas equation	$PV = nRT$
De Broglie relation	$\lambda = h / mv$
Free energy	$G = H - TS$
Arrhenius equation	$k = Ae^{-E_a/RT}$
$E = hv$	
$\Delta U = q + w$	
$\Delta G = \Delta G^\circ + RT \ln Q$	$\Delta G = -nFE$
$w = -P\Delta V$	

Standard atmosphere = 101325 Pa

RT at 298.15 K = 2.4790 kJ mol⁻¹

Pi (π) = 3.1415927

$1 \text{ \AA} = 10^{-10} \text{ m}$		$1 \text{ W} = 1 \text{ J s}^{-1}$
$1 \text{ J} = 1 \text{ kg m}^2 \text{ s}^{-2}$		$1 \text{ cal} = 4.184 \text{ J}$
$1 \text{ Pa} = 1 \text{ kg m}^{-1} \text{ s}^{-2} = 1 \text{ N m}^{-2}$		$1 \text{ bar} = 10^5 \text{ Pa}$
$1 \text{ atm} = 1.01325 \times 10^5 \text{ Pa} = 760 \text{ mmHg (torr)}$		
$1 \text{ eV / molecule} = 96.4853 \text{ kJ mol}^{-1}$		

IUPAC Periodic Table of the Elements

18

		Key																																																																																																																																																																																	
		atomic number		Symbol		name		standard atomic weight																																																																																																																																																																											
1	H hydrogen 1.007 84(7)	2	He helium 4.002 602(2)	3	Li lithium 6.941(2)	4	Be beryllium 9.012 182(2)	5	B boron 10.811(7)	6	C carbon 12.0107(8)	7	N nitrogen 14.0064(2)	8	O oxygen 15.999 4(3)	9	F fluorine 18.998 4032(3)	10	Ne neon 20.1797(6)	11	Na sodium 22.989 769(2)	12	Mg magnesium 24.3050(6)	13	Al aluminum 26.981 538(6)	14	Si silicon 28.0855(3)	15	P phosphorus 30.973 761(2)	16	S sulfur 32.06(5)	17	Cl chlorine 35.448(2)	18	Ar argon 39.948(1)	19	K potassium 39.0983(1)	20	Ca calcium 40.078(4)	21	Sc scandium 44.955 912(6)	22	Ti titanium 47.867(1)	23	V vanadium 50.9415(1)	24	Cr chromium 51.9961(6)	25	Mn manganese 54.938 045(3)	26	Fe iron 55.845(2)	27	Co cobalt 58.933 208(6)	28	Ni nickel 58.6934(2)	29	Cu copper 63.546(3)	30	Zn zinc 65.38(4)	31	Ga gallium 69.723(1)	32	Ge germanium 72.64(1)	33	As arsenic 74.921 602(2)	34	Se selenium 78.96(3)	35	Br bromine 79.904(1)	36	Kr krypton 83.798(2)	37	Rb rubidium 85.4678(3)	38	Sr strontium 87.62(1)	39	Y yttrium 88.905 85(2)	40	Zr zirconium 91.224(2)	41	Nb niobium 92.906 38(2)	42	Mo molybdenum 95.94(2)	43	Tc technetium 97.907(2)	44	Ru ruthenium 101.07(2)	45	Rh rhodium 102.905 50(2)	46	Pd palladium 106.42(1)	47	Ag silver 107.8682(2)	48	Cd cadmium 112.411(8)	49	In indium 114.818(3)	50	Sn tin 118.710(7)	51	Sb antimony 121.760(1)	52	Te tellurium 127.60(3)	53	I iodine 126.904 47(3)	54	Xe xenon 131.29(8)	55	Cs cesium 132.905 45(2)	56	Ba barium 137.327(7)	57-71	Lanthanoids	72	Hf hafnium 178.49(2)	73	Ta tantalum 180.9479(1)	74	W tungsten 183.84(1)	75	Re rhenium 186.207(1)	76	Os osmium 190.23(2)	77	Ir iridium 192.222(1)	78	Pt platinum 195.084(2)	79	Au gold 196.966 57(2)	80	Hg mercury 200.59(2)	81	Tl thallium 204.38(3)	82	Pb lead 207.2(1)	83	Bi bismuth 208.980 4(2)	84	Po polonium [209]	85	At astatine [210]	86	Rn radon [222]	87	Fr francium [223]	88	Ra radium [226]	89-103	actinoids	104	Rf rutherfordium [261]	105	Db dubnium [262]	106	Sg seaborgium [263]	107	Bh bohrium [264]	108	Hs hassium [277]	109	Mt meitnerium [268]	110	Ds darmstadtium [271]	111	Rg roentgenium [272]	112	Cn copernicium [285]	113	Nh nihonium [286]	114	Fl flerovium [289]	115	Mc moscovium [288]	116	Lv livermorium [293]	117	Ts tennessine [294]	118	Og oganesson [294]

57	La lanthanum 138.905(2)	58	Ce cerium 140.12(1)	59	Pr praseodymium 140.907 6(2)	60	Nd neodymium 144.24(1)	61	Pm promethium [144.9127]	62	Sm samarium 150.36(1)	63	Eu europium 151.964(1)	64	Gd gadolinium 157.25(3)	65	Tb terbium 158.925 34(2)	66	Dy dysprosium 162.500(1)	67	Ho holmium 164.930 32(2)	68	Er erbium 167.258(2)	69	Tm thulium 168.934 2(2)	70	Yb ytterbium 173.054(3)	71	Lu lutetium 174.967(1)
89	Ac actinium [227.0277]	90	Th thorium 232.037(7)	91	Pa protactinium [231.03688]	92	U uranium 238.028 91(3)	93	Np neptunium [237.04817]	94	Pu plutonium [244.06422]	95	Am americium [243.06114]	96	Cm curium [247.07127]	97	Bk berkelium [247.06533]	98	Cf californium [251.07887]	99	Es einsteinium [252.08322]	100	Fm fermium [257.0851]	101	Md mendelevium [258.10386]	102	No nobelium [259.10136]	103	Lr lawrencium [260.10536]



Notes

- 'Aluminium' and 'caesium' are commonly used alternative spellings for 'aluminum' and 'cesium'.
- IUPAC 2001 standard atomic weights (mean relative atomic masses) are listed with uncertainties in the last figure in parentheses (i.e. D. Loss, Pure Appl. Chem. 76, 1107-1122 (2004)). These values correspond to current best knowledge of the elements in natural terrestrial sources. For elements with no IUPAC assigned standard value, the atomic mass (in unified atomic mass units) or the mass number of the nuclide with the longest known half-life is listed between square brackets.
- Elements with atomic numbers 112, 113, 114, 115, and 116 have been reported but not fully authenticated.

Copyright © 2004 IUPAC, the International Union of Pure and Applied Chemistry. For updates to this table, see http://www.iupac.org/reports/periodic_table/. This version is dated 1 November 2004.

Problem 1: Separation and Identification of Ions

A student studied the chemical reactions between cations, A^{2+} , B^{2+} , C^{2+} , D^{2+} , E^{2+} in nitrate aqueous solutions and anions X^- , Y^- , Z^- , Cl^- , OH^- in sodium aqueous solutions as well as an organic ligand L. Some precipitation (ppt) products and colored complexes were found as shown in Table 1:

Table 1

	X^-	Y^-	Z^-	Cl^-	OH^-	L
A^{2+}	***	***	***	***	White ppt	***
B^{2+}	Yellow ppt	White ppt	***	***	***	BL_n^{2+} Complex
C^{2+}	White ppt	Brown ppt	Brown ppt	White ppt	Black ppt	CL^{2+} , CL_2^{2+} Complexes
D^{2+}	***	Red ppt	***	***	***	***
E^{2+}	***	Red ppt	White ppt	***	***	***

*** = No reaction,

- 1-1 Design a flow chart for the separation of A^{2+} , B^{2+} , C^{2+} , D^{2+} , E^{2+} in a nitrate aqueous solution by using various aqueous solutions containing anions X^- , Y^- , Z^- , Cl^- , OH^- , respectively, as testing reagents. Write down the product of the chemical reaction for each step in the flow chart.
- 1-2 Design a flow chart for the separation of anions X^- , Y^- , Z^- , Cl^- , OH^- in a sodium aqueous solution by using various aqueous solutions containing cations A^{2+} , B^{2+} , C^{2+} , D^{2+} , E^{2+} , respectively, as testing reagents. Write down the product of the chemical reaction for each step in the flow chart.
- 1-3 The white ppt BY_2 and brown ppt CY_2 have low solubilities in water with solubility products (Ksp) of 3.20×10^{-8} and 2.56×10^{-13} , respectively at $25^\circ C$.
- 1-3-1 Calculate the solubility of BY_2 .
- 1-3-2 Calculate the solubility of CY_2 .
- 1-4 A series of solutions containing B^{2+} and L were prepared in 50 mL volumetric flasks by adding a 2 mL of 8.2×10^{-3} M solution of B^{2+} to each flask. Varying amounts of a 1.0×10^{-2} M solution of the ligand L are added to each flask. The solution in each volumetric flask was diluted with water to the mark (50 mL). The absorbance (A) of Complex BL_n was measured at 540 nm for each solution in a 1.0 cm cell. The data are summarized in Table 2. (Both B^{2+} and ligand L show no absorption ($A = 0$) at 540 nm.) [Mole Ratio Method]
- 1-4-1 Calculate the value of n (Coordination number) in the complex BL_n^{2+} .

1-4-2 Calculate the formation constant (K_f) of complex BLn^{2+} .

Table 2

Added L V_L (mL)	Absorbance (A)	Added L V_L (mL)	Absorbance (A)
1.00	0.14	2.00	0.26
3.00	0.40	4.00	0.48
5.00	0.55	6.00	0.60
7.00	0.64	8.00	0.66
9.00	0.66	10.00	0.66

1-5 Solid NaY (soluble) was added very slowly to an aqueous solution containing 0.10 M in B^{2+} and 0.05 M in C^{2+} prepared from their respective nitrate aqueous salts.

1-5-1 Which cation (B^{2+} or C^{2+}) precipitates first? What is the $[Y^-]$ when this happens? ($K_{sp} = 3.20 \times 10^{-8}$ for BY_2 and $K_{sp} = 2.56 \times 10^{-13}$ for CY_2 , at $25^\circ C$.) [Separation by Precipitation]

1-5-2 What are the concentrations of Y^- and the remaining cation when complete precipitation of the first precipitating cation has occurred (assume that the concentration of the first cation in solution after complete precipitation is $\leq 10^{-6}$ M)? Is it possible to separate B^{2+} and C^{2+} by the precipitation method with Y^- ion as a precipitating agent?

Problem 2: Preparation and Applications of Radioisotopes

Radioisotopes can be used in medical diagnosis and therapy as well as industrial analysis. Many radioisotopes, e.g. P-32 (Mass number = 32) and Co-60 can be generated by the irradiation of neutrons in a nuclear reactor. However, some radioisotopes in nature, e.g. C-14 and T-3 (Tritium), can be produced by the bombardment of nitrogen N-14 atoms in the atmosphere by neutrons in the cosmic ray. (Atomic numbers of T & H, C, N, P, Co and neutron are 1, 6, 7, 15, 27 and 0, respectively. P-32 can be denoted as $^{32}_{15}P$)

2-1 Write down the equations for the nuclear reactions for the production of C-14 and T-3 by the bombardment of nitrogen N-14 atoms in the atmosphere with neutrons in the cosmic ray.

Radioisotope C-14 can be used as a reagent in C-14 dating. The activity (A) in terms of counts per minute (cpm) of the radioisotope C-14 is proportional to the number (N) of C-14 atoms as follows: [C-14 Dating]

$$A = \epsilon N \quad (1)$$

Where ϵ is the detection coefficient of a detector for C-14 and λ is the decay constant of C-14. An initial amount (N_0) of C-14 can be reduced to the amount (N) of C-14 by decay after a given time (t) as follows:

$$N = N_0 e^{-\lambda t} \quad (2)$$

The half life ($t_{1/2}$) of C-14 is 5730 years which is defined as the time required for 50% of the number of the radioisotope C-14 atoms in a sample to undergo decay, that is $N = 1/2 N_0$. It is well known that activity (A_0) of C-14 in a living animal or plant is kept to be around 16.5 cpm/g of carbon. After the death of the animal or plant, the activity (cpm/g of carbon) of C-14 in the body of the living animal or plant is decreased by the time passed.

2-2-1 Give the equation showing the relation between the original activity (A_0) and final activity (A) as function of time for a living animal or plant.

2-2-2 The activity of C-14 in an ancient wood boat is found to be 10.2 cpm/g of carbon. Calculate the age of the ancient boat.

2-3 The radioisotope P-32 is a very important leveling reagent for biological research and can be produced by the bombardment of P-31 by a neutron in a nuclear reactor. The production rate (R_p) of P-32 can be estimated as :

$$R_p = N \delta \quad (3)$$

Where N and δ are the number of atoms and neutron capture cross section ($\approx 0.9 \times 10^{-24}$ cm²/atom) of P-31, respectively, and ϕ is the neutron flux (neutron / (cm² sec)) of the nuclear reactor. If the detection efficient (ϵ) of the detector for P-32 is 1.0, the decay rate (R_d) and the activity (A) of P-32 in the nuclear reactor can be approximately estimated as a function of the number (N^*) of P-32 atoms as follows:

$$R_d = N^* \lambda \quad (4)$$

and
$$A = \lambda N^* = R_p - R_d \quad (5)$$

Where λ is the decay constant of P-32, t is the neutron irradiation time in the nuclear reactor and the half life ($t_{1/2}$) of P-32 is 14.3 days.

2-3-1 A 10 mg sample of pure H₃PO₄ is irradiated by neutrons with a neutron flux of 1.00×10^{13} n cm⁻² sec⁻¹ for one hour in a nuclear reactor. Calculate the activity of the sample in cps (counts / second) and Ci. (Ci = Curie, 1 Ci $\approx 3.7 \times 10^{10}$ cps, atomic weight: H=1, P=31, O=16)

2-3-2 The radioisotope P-32 can be used to measure the volume of water in a pool or the blood volume of an animal. A 2.0 mL solution of 1.0 Ci/mL P-32 was injected into a pool. After mixing well, the activity of 1.0 mL of water in the pool was found to be 12.4 cps (counts / second). Calculate the volume of water (L) in the pool. (Ci = Curie, 1 Ci $\approx 3.7 \times 10^{10}$ cps)

Problem 3: Ion Exchangers

Ion exchangers can be employed to adsorb and separate cations and anions. They can be prepared from organic or inorganic materials. An organic, cationic ion exchanger can be synthesized by the polymerization of styrene / divinyl benzene followed by sulfonation with H₂SO₄,

as shown in Scheme 1:

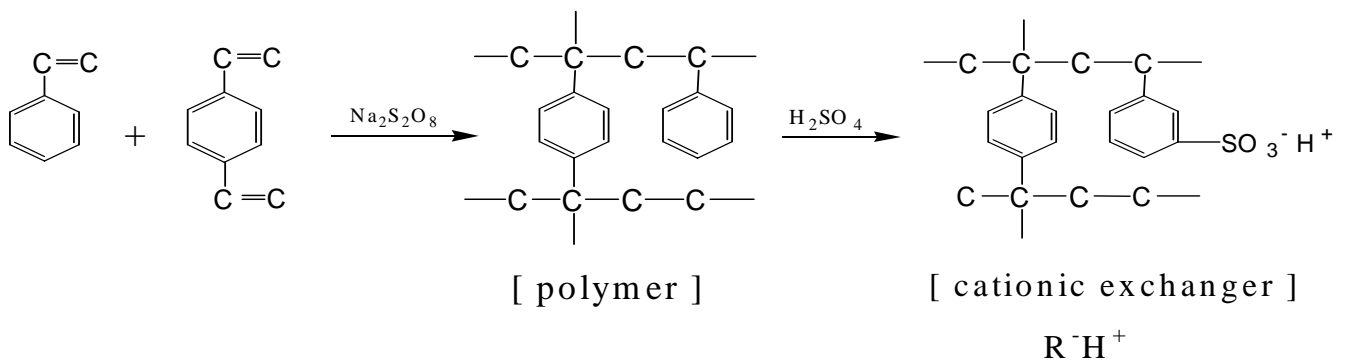

[Scheme 1]

Cationic ion exchanger (denoted as R^-H^+) can be employed to adsorb the cations, M^+ , the chemical reaction and the equilibrium constant K_c as well as the distribution coefficient K_d can be expressed as follows:



The cationic ion exchanger R^-H^+ can be transformed into the ion exchanger R^-M^+ or R^-M^{z+} by the reaction of R^-H^+ with a metal hydroxide ($M(OH)_z$). The approximate equations are:

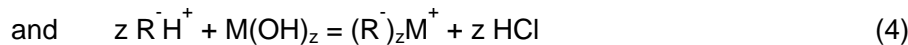

3-1 A cationic ion exchanger R^-Na^+ was employed to remove $CaCl_2$ in tap water,

3-1-1 Give the chemical equation for the adsorption of Ca^{2+} by the cationic ion exchanger R^-Na^+ .

3-1-2 If another ion exchanger R^-H^+ is employed instead of R^-Na^+ . (a) Give the chemical equation for the adsorption of Ca^{2+} by the ion exchanger R^-H^+ and (b) tell which ion exchanger, R^-H^+ or R^-Na^+ , is suitable for drinking purpose and give the reason.

3-2 An organic, anionic ion exchanger (denoted as R^+Cl^-) can also be synthesized by the polymerization of styrene / divinyl benzene followed by the reaction of the resulting polymer, poly (styrene / divinyl benzene), with the Lewis acid $AlCl_3$ and tertiary amine NR'_3 , as shown in Scheme 2:

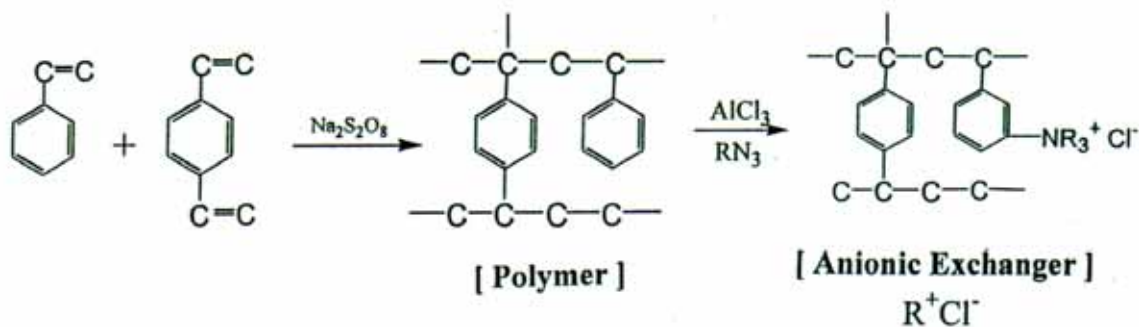

[Scheme 2]

The anionic ion exchanger R^+OH^- can be obtained from the chemical reaction of the ion exchanger R^+Cl^- with 3.0 M of NaOH by the equation:



3-2-1 Tell how the removal of H^+ from a solution of HCl can be achieved with an anionic ion exchanger and give the chemical equation for the process.

3-2-2 Tell how the amount of SO_4^{2-} in tap water can be estimated by using an anionic ion exchanger R^+OH^- . Give all of the chemical equations involved in the process.

The capacity (S) of the cationic ion exchanger R^+H^+ for an adsorbed ion can be expressed in moles of the adsorbed ion per gram of the ion exchanger in 1.0 mL of aqueous solution and can be calculated by using the following equation:

$$S = ([RM] + [RH]) \times 10^{-3} \quad (6)$$

The capacity (S) of the cationic ion exchanger R^+H^+ for M^+ ions in an aqueous solution can be estimated from the equilibrium constant K_c , the distribution coefficient K_d and the concentrations of M^+ and H^+ ions in the aqueous solution.

3-3 Show that the relationship between K_d , S, K_c , $[M^+]$ and $[H^+]$ as shown by the equation:

$$1 / K_d = [M^+] / (S(10^3)) + [H^+] / (S K_c(10^3)) \quad (7)$$

3-4 Ion exchangers can be employed as stationary phase materials in liquid chromatography to adsorb and separate various ions. For example, the anionic ion exchanger R^+OH^- can be used to separate X^- and Y^- ions with the eluent NaOH. The chromatogram for separation of X^- and Y^- ions using a 30 cm of anionic ion exchange column is shown in Figure 1.

Where t_1 , t_2 and t_0 are the retention times (t_R) for X^- , Y^- and the pure eluent (NaOH) to traverse the column, respectively. ω_1 and ω_2 are the peak-widths for X^- and Y^- . The number of theoretical plates N and the plate height H (height equivalent of the theoretical plates) of the column can be estimated as shown below:

$$N = 16 (t_R / \omega)^2 \quad (8)$$

and $H = L / N \quad (9)$

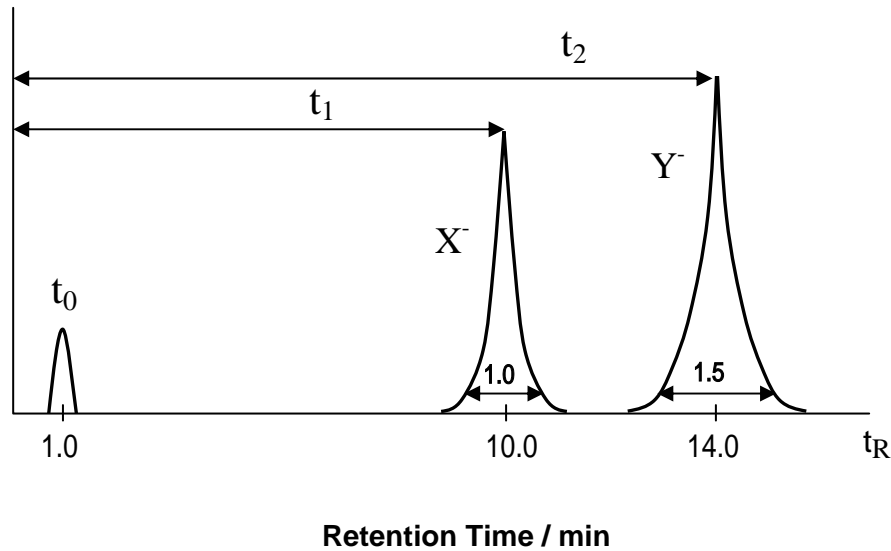

Figure 1. Liquid Chromatogram for X^- and Y^- ions

where L is the length of the column. The resolution (R) of the column and the separation factor (α) for X^- and Y^- also can be estimated using the following equations:

$$R = 2 (t_2 - t_1) / (\omega_1 + \omega_2) \quad (10)$$

and $\alpha = (t_2 - t_0) / (t_1 - t_0) \quad (11)$

3-4-1 Calculate the average number of theoretical plates N of the column.

3-4-2 Calculate the plate height H of the column.

3-4-3 Calculate the resolution (R) of the column for X^- and Y^- ions.

3-4-4 Calculate the separation factor (α) for X^- and Y^- ions.

3-5 Some ion exchangers are derived from inorganic matters. Zeolites $[(M^{Z+})(Al_2O_3)_m / (SiO_2)_n]$ ($M^{Z+} = Na^+, K^+$ or Ca^{2+}, Mg^{2+}) are the best known examples of inorganic ion exchangers. Some examples of Zeolites are shown in Figure 2.

A Na^+ -Zeolite (denoted as $Z-Na^+$) with a pore size of 13 Å is an important ion exchanger for the removal of Ca^{2+} or Mg^{2+} ion from tap water. Zeolites with definite pore sizes also behave as highly selective adsorbents for various molecules, e.g. H_2O and iso-butane. Thus, the zeolite can be used as a molecular sieve. The zeolite can also be used as a catalyst by adsorption of a petroleum component, e.g. iso-butane, in petroleum resulting in the enhancement of rate of the cracking of the adsorbed component.

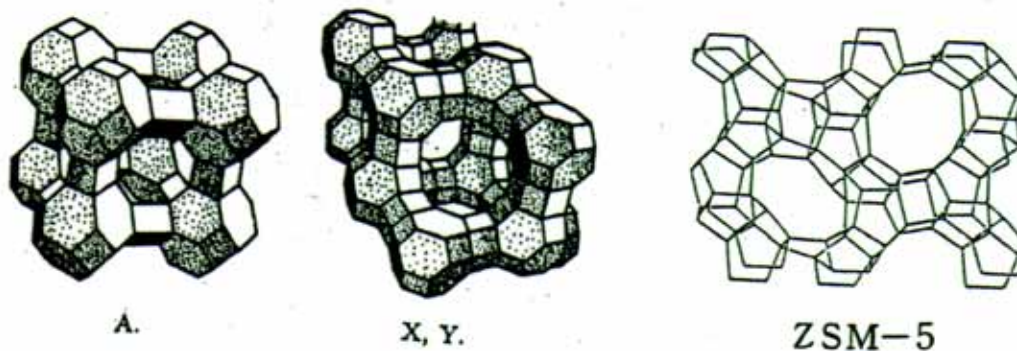

Figure 2. Various types of Zeolites

3-5-1 Give the chemical equation for the removal of Ca^{2+} ions from tap water with Z-Na^+ zeolite ion exchange column.

3-5-2 Give the chemical equation for the adsorption of K^+ with Z-Na^+ zeolite.

Problem 4: Determination of Calcium Ion by Precipitation Followed by Redox Titration

The calcium content of an aqueous sample can be determined by the following procedure:

Step 1 A few drops of methyl red are added to the acidified aqueous sample, followed by thorough mixing with $\text{Na}_2\text{C}_2\text{O}_4$ solution.

Step 2 Urea ($(\text{NH}_2)_2\text{CO}$) is added and the solution gently boil until the indicator turns yellow (this typically takes 15 min). CaC_2O_4 precipitates out.

Step 3 The hot solution is filtered and the solid CaC_2O_4 is washed with ice-cold water to remove excess $\text{C}_2\text{O}_4^{2-}$ ions.

Step 4 The insoluble CaC_2O_4 is dissolved in hot 0.1 M H_2SO_4 to give Ca^{2+} ions and $\text{H}_2\text{C}_2\text{O}_4$. The dissolved $\text{H}_2\text{C}_2\text{O}_4$ is titrated with standardized KMnO_4 solution until the purple end point is observed.

Relevant reactions and equilibrium constants:

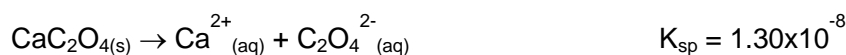



- 4-1 Write a balanced equation for the reaction that takes place upon the addition of urea (Step 2).
- 4-2 The calcium content of a 25.00 mL aqueous sample was determined using the above procedure and found to require 27.41 mL of a 2.50×10^{-3} M KMnO_4 solution in the final step. Find the concentration of Ca^{2+} ions in the sample.
- 4-3 Calculate the solubility of CaC_2O_4 in an aqueous solution buffered at pH 4.0. (Neglect activity coefficients)

In the above analysis, a possible source of error was neglected. The precipitation of CaC_2O_4 in Step 1 will be incomplete if an excess of $\text{C}_2\text{O}_4^{2-}$ ions is added, due to the following reactions:

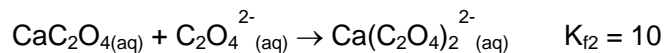
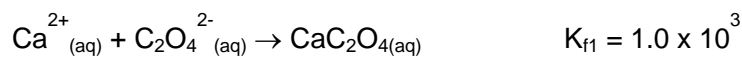

- 4-4 Calculate the equilibrium concentrations of Ca^{2+} and $\text{C}_2\text{O}_4^{2-}$ ions in solution after optimal precipitation of CaC_2O_4 is reached.
- 4-5 Calculate the concentrations of H^{+} and Ca^{2+} in a saturated solution of CaC_2O_4 . (Neglect activity coefficients. Any assumptions made during calculation must be clearly stated.)

Problem 5: Nitrogen in Wastewater

In natural water and waste water, the forms of nitrogen of greatest interest are nitrate, nitrite, ammonia, and organic nitrogen. All these forms of nitrogen, as well as nitrogen gas, are biochemically interconvertible and are components of the nitrogen cycle.

- 5-1 The Macro-kjeldahl method, in combination with a titration method, is often used in the

determination of organic nitrogen in wastewater. In the first step, H_2SO_4 , K_2SO_4 , and HgSO_4 are added to the sample solution. After digestion, the solution is neutralized by the addition of concentrated NaOH . The gas liberated by the treatment is then distilled into a solution of excess boric acid and the latter subsequently titrated with 0.02 N H_2SO_4 .

5-1-1 Identify the product formed in the digestion step.

5-1-2 Identify the gas liberated upon the addition of NaOH .

5-1-3 Write a balanced equation for the reaction between the liberated gas and boric acid.

5-1-4 Write a balanced equation for the final titration step.

5-1-5 Which of the following indicators is most suitable to be used in the final titration step:

Methyl orange (transition range pH 3.1 - 4.4), phenolphthalein (transition range pH 8.0 - 9.6) is chosen as the indicator. Explain your choice.

5-2 Nitrite is known to cause the illness methemoglobinemia in infants. In the laboratory, nitrite can be determined by a colorimetric method. The method requires the preparation of a series of standard nitrite solutions. However, nitrite is readily oxidized in the presence of moisture and hence standardization of the stock nitrite solution is required in order to achieve high accuracy in the subsequent analysis. The standardization is carried out by adding a known excess of standard KMnO_4 solution and H_2SO_4 solution are added into the nitrite stock solution. The purple color of the solution due to the presence of excess permanganate was subsequently discharged by the addition of a known quantity of $\text{Na}_2\text{C}_2\text{O}_4$ and the mixture back titrated with standard permanganate solution.

5-2-1 Write a balanced equation for the reaction of the nitrite solution with KMnO_4 .

5-2-2 Write a balanced equation for the back titration.

5-2-3 Write a mathematical equation for calculation of nitrogen concentration.

A: mg/ml N in stock NaNO_2 solution

B: total ml standard KMnO_4 used

C: molarity of standard KMnO_4

D: total ml standard $\text{Na}_2\text{C}_2\text{O}_4$ solution

E: molarity of standard $\text{Na}_2\text{C}_2\text{O}_4$

F: ml stock NaNO_2 solution taken for titration

Problem 6: Use of Isotopes in Mass Spectrometry

Many elements in the periodic table have more than one isotope. The atomic mass of an element is calculated based on the relative abundance of the isotopes. As an example, the atomic mass of chlorine is about 35.5 because the abundance of Cl^{35} is about three times the abundance of Cl^{37} . In mass spectrometry, instead of average atomic mass, the isotope peaks are observed. (Cl^{35} 75.77%, Cl^{37} 24.23%, C^{12} 98.9%, C^{13} 1.1%, Br^{79} 50.7%, Br^{81} 49.3%)

Isotopes are quite useful in quantitative mass spectrometry.

- 6-1 In addition to the retention time (migration time), the ratio of M and M+2 ions was used as the qualitative criteria in the analysis of 2,3,7,8, tetra chlorinated dioxin (2,3,7,8-TCDD) by gas chromatography / mass spectrometry. Calculate the theoretical ratio of the two ions. The intensities of the isotopic species can be found by applying the following formula: $(a+b)^n$, where a is the relative abundance of the light isotope, b is the relative abundance of the heavy isotope, and n is the number of chlorine atoms present.
- 6-2 Molecular ion is often selected in quantitative analysis. The intensity of the molecular ion needs to be corrected if the signal is interfered by other compounds. In the analysis of a non-halogenated compound with a molecular weight of 136, the molecular ion was selected for quantitative analysis. Propose a mathematical equation for calculation the corrected signal, if the analyte co-elutes (same migration time) with the compound n-butyl bromide.

Problem 7: Atomic Orbitals

One way to describe the shape of atomic orbitals of H-atom is in terms of the nodal surfaces, or nodes, where the electron has zero probability. According to wave mechanics, the number of nodes increases as n increases. For given set of orbitals nlm , there are " $n-l-1$ " spherical nodes, " l " angular nodes.

- 7-1 Describe the electron probability distribution for the 1s, 2s and 3s orbitals. How many nodes does each orbital have respectively?
- 7-2 Describe the electron probability distribution for the $2p_z$ and $3p_z$ orbitals. How many nodes does each orbital have respectively?
- 7-3 Imagine that you are traveling along the z axis, beginning your journey at a distance far from the nucleus on the z axis, passing through the nucleus to a distant point on the $-z$ axis. How many nodal surfaces would you pass through for each of the following orbitals: 1s, 2s, 3s, $2p_z$ and $3p_z$.

Problem 8: Intermolecular Forces

Intermolecular forces occur between, rather than within, molecules. Ion-dipole interaction and dipole-dipole interaction are two common types of intermolecular forces.

Part 1: Ion-Dipole Interactions

The bonding of an ion, such as Na^+ , with a polar molecule, such as water, is an example of an ion-dipole interaction. Shown below are a sodium ion, a water molecule, and a crown ether compound.

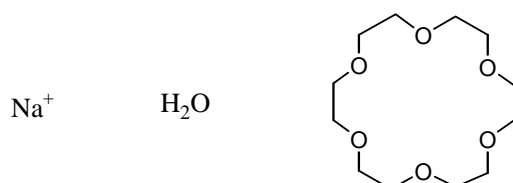

- 8-1-1 Draw the geometrical structure of the product resulting from the interaction between the sodium ion and water molecules.

8-1-2 Draw a diagram showing the interaction between the sodium ion and the crown ether molecule.

Part 2: Dipole-Dipole Interactions

A hydrogen bond may be regarded as a particular kind of dipole-dipole interaction. Strong hydrogen bonding forces are seen among molecules in which hydrogen is bound to a highly electronegative atom, such as nitrogen, oxygen, or fluorine.

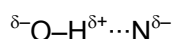

Compared to other intermolecular forces, hydrogen bonds are relatively strong; their energies are of the order of 15 to 40 kJ/mol. Hydrogen bonding is so strong that, in some cases, it survives even in a vapor.

8-2-1 In gaseous hydrogen fluoride, many of the HF molecules are associated into $(\text{HF})_6$. Draw the structure of this hexamer.

8-2-2 Draw a diagram showing the hydrogen-bonding interactions between two acetic acid ($\text{CH}_3\text{CO}_2\text{H}$) molecules.

Part 3: Hydrogen-bonding in Living Matter

Some chemical reactions in living matter involve complex structures such as proteins and DNA, and in these reactions certain bonds must be easily broken and reformed. Hydrogen bonding is the only type of bonding with energies of just the right magnitude to allow this.

The key to DNA's functioning is its double-helical structure with complementary bases on the two strands. The bases form hydrogen bonds to each other.

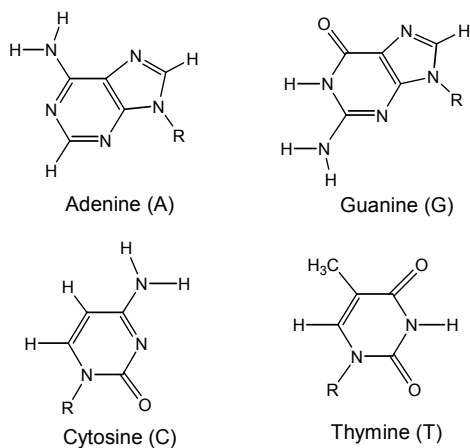

The organic bases found in DNA

- 8-3 There are two kinds of hydrogen-bonded base pairs, T-A and G-C, in DNA. Draw these two base pairs, showing the hydrogen-bonding interactions.

Problem 9: Crystal Packing

There are three cubic unit cells for the atomic solids, namely, simple cubic, body-centered cubic and face-centered cubic. They are illustrated in the following figures:

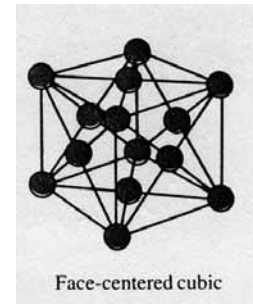
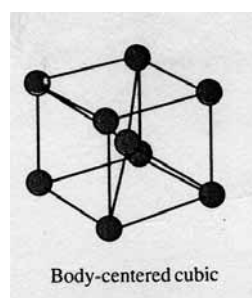
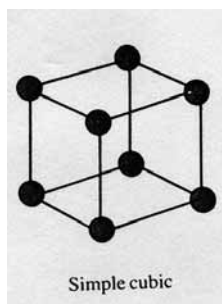

- 9-1 How many nearest neighbor atoms are in each packing, respectively?
- 9-2 In each packing, the packing efficiency is defined by

$$f_v = \frac{\text{volume occupied by spheres in the unit cell}}{\text{volume of the unit cell}}$$

What is the value of f_v in each type of packing, respectively?

- 9-3 Silver crystallizes in a cubic closest packed structure, i.e. face-centered cubic. The radius of a silver atom is 144 pm. Calculate the density of silver.
- 9-4 X-ray diffraction is commonly used for the determination of crystal structures. In one such determination, the emitted X rays were diffracted by a LiF crystal ($d = 201$ pm), and the first-order diffraction was detected at an angle of 34.68° . Calculate the wavelength of the X-ray emitted by the metal.

Problem 10: Applications of Transition Metals

The transition metal elements are widely distributed in the Earth's crust. Many of these elements find uses in everyday objects: iron pipes, copper wiring, chromium auto parts, etc.

Part 1: Properties of Chromium

Chromium is a silvery-white, lustrous metal, whose name (from the Greek chroma, meaning color) alludes to its many colorful compounds. The bright colors of chromium (VI) compounds lead to their use in pigments for artists paints and ceramic glazes.

10-1-1 In an acidic solution, the yellow chromate ion (CrO_4^{2-}) changes into the orange dichromate ion ($\text{Cr}_2\text{O}_7^{2-}$). Write the equation for the reaction.

10-1-2 What is the oxidation state of each metal center in the chromate ion and the dichromate ion?

10-1-3 Is this a redox reaction? Explain.

10-1-4 What is the main factor that controls the equilibrium position?

10-1-5 Draw the three-dimensional structures of CrO_4^{2-} and $\text{Cr}_2\text{O}_7^{2-}$.

Part 2: Uses of Chromium

An antique automobile bumper is to be chrome plated. The bumper is dipped into an acidic $\text{Cr}_2\text{O}_7^{2-}$ solution where it serves as the cathode of an electrolytic cell. (The atomic mass of Cr is 51.996; $1 F = 96,485 C.$)

10-2-1 Given that oxidation of H_2O occurs at the anode, write equation for the two half-reactions and the overall cell reaction.

10-2-2 How many moles of oxygen gas will be evolved for every 52.0 g of chromium deposited?

10-2-3 If the current is 10.0 amperes, how long will it take to deposit 52.0 g of chromium onto the bumper?

10-2-4 What is the chemical reason that chromium is so useful for decorative plating on metals?

Problem 11: Electrochemistry of Inorganic Compounds

Some inorganic compounds exhibit a variety of oxidation states, for example, many Mn compounds are known with oxidation states ranging from 0 to +7. The standard reduction potential of a half reaction is measured against the hydrogen electrode. In this problem, the reduction $\text{Mn}^{2+} + 2\text{e}^- \rightarrow \text{Mn}$, $E^\circ = -1.18\text{V}$ is expressed as $\text{Mn}^{2+} (-1.18) \text{Mn}$. For Mn in acidic solution the reduction series: $\text{Mn}^{3+} \quad \text{Mn}^{2+} \quad \text{Mn}$ can be represented as follows:

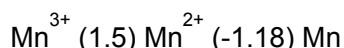

A redox reaction takes place spontaneously if the redox potential is positive. A Frost diagram, a plot of nE° (n is the number of electron transferred in the half reaction) of the reduction couple $\text{X}(N) / \text{X}(0)$ against the oxidation number, N , of the element, is used to indicate the most stable species of the compounds in different oxidation states. The Frost diagram of $\text{Mn}^{3+} / \text{Mn}^{2+} / \text{Mn}$ is shown below.

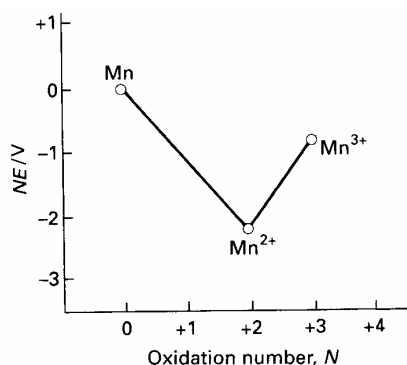

11-1 The reduction potential depends on the concentration of the species in solution. The K_{sp} of MnCO_3 is 1.8×10^{-11} . Use the Nernst equation to determine the potential at 25°C for the voltaic cell consisting of $\text{Mn}_{(\text{s})} | \text{Mn}^{2+}_{(\text{aq})} (1\text{M}) || \text{Mn}^{2+}_{(\text{aq})} / \text{MnCO}_3 | \text{Mn}_{(\text{s})}$, if the concentration of Mn^{2+} in the right hand side of the cell is $1.0 \times 10^{-8} \text{M}$.

11-2 For oxygen, the standard reduction potential in acidic solution can be represented as: $\text{O}_2 (0.70) \text{H}_2\text{O}_2 (1.76) \text{H}_2\text{O}$. Construct the Frost diagram for oxygen, and use the information contained in the diagram to calculate the reduction potential of the half reaction for reduction of O_2 to H_2O . Could H_2O_2 undergo disproportionation spontaneously?

Xenon difluoride can be made by placing a vigorously dried flask containing xenon gas and fluorine gas in the sunlight. The half-reaction for the reduction of XeF_2 is shown below:

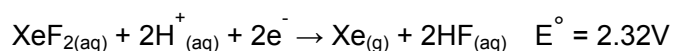

11-3 Use the VSEPR model to predict the number of electron-pairs and molecular geometry of

XeF₂. Show that XeF₂ decomposes in aqueous solution, producing O₂, and calculate the E° for the reaction. Would you expect this decomposition to be favored in an acidic or a basic solution? Explain.

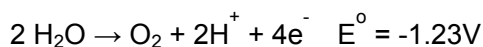

Problem 12: Metal Carbonyl Compounds

Carbon monoxide, as a two electron donor ligand, coordinates to transition metals to form metal carbonyl compounds. For example, iron forms the pentacarbonyl metal complex, Fe(CO)₅. Nickel tetracarbonyl, Ni(CO)₄, has been used for the purification of Ni metal in the Mond process. Electron counts of these metal carbonyl complexes show that they obey the 18-electron rule. Cobalt and manganese react with CO to form dinuclear complexes Co₂(CO)₈ and Mn₂(CO)₁₀, respectively. (Electronic configuration of Mn is [Ar](3d)⁵(4s)²) A metal-metal bond between the metal centers is considered essential in order for the compounds to obey the 18 electron rule. The cyclopentadienyl anion C₅H₅⁻ has also been widely used as a η⁵-ligand. For example, ferrocene (C₅H₅)₂Fe, a classical compound, obeys the 18 electron rule.

The reaction of W(CO)₆ with sodium cyclopentadienide NaC₅H₅ yields an air sensitive compound **A**. Oxidation of **A** with FeSO₄ yields compound **B**. Compound **A** can also be prepared from the reaction of **B** with Na/Hg, a strong reducing agent. In the 1600-2300 cm⁻¹ region of the IR spectrum, **A** shows absorption bands at 1744 and 1894 cm⁻¹ and **B** absorption bands at 1904, and 2010 cm⁻¹. Compound **A** is a strong nucleophile and a good starting material for the synthesis of organometallic compounds containing metal-carbon bonds. The reaction of **A** with propargyl bromide (HC≡CCH₂Br) gives compound **C** containing a metal-carbon σ-bond. At room temperature compound **C** undergoes a transformation to yield compound **D**. The same chemical composition was found for compounds **C** and **D**. The chemical shifts (δ) of the CH₂ and CH resonances and coupling constants J_{H-H} of propargyl bromide, **C** and **D** in the respective ¹H NMR spectra are listed in the following table.

¹ H NMR	HC≡CCH ₂ Br	C	D
δ (CH ₂)	3.86	1.90	4.16
δ (CH)	2.51	1.99	5.49
J _{H-H} (Hz)	2.7	2.8	6.7

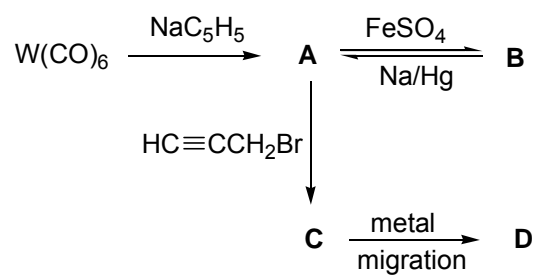

- 12-1 Explain the differences in the IR spectra of **A** and **B**.
- 12-2 Draw chemical structures for **A**, **B**, **C** and **D**.
- 12-3 The transformation of **C** to **D** involves a migration of the metal on the propargyl ligand. If $\text{DC}\equiv\text{CCH}_2\text{Br}$ is used for the synthesis of **C**, draw the structures of **C** and **D**.

Problem 13: Carbocations and Aromaticity

Carbocations are reactive intermediates having a charge of +1 on the central carbon atom, with three groups attached. The carbocation center is electron deficient and lies in the same plane of the three attached atoms. Proton NMR is one of the primary instrumental methods applied to determine the structure and properties of carbocations. In a superacid media, such as SbF_5 , stable carbocations can be generated and directly observed by NMR. SbF_5 is a strong Lewis acid that complexes with a weak base such as F^- to form SbF_6^- .

13-1 What is the product **A** in the following reaction?

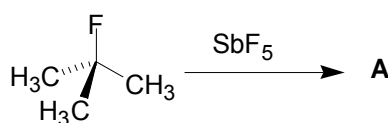

13-2 Two proton NMR spectra of $(\text{CH}_3)_3\text{CF}$ were obtained using neat $(\text{CH}_3)_3\text{CF}$ and $(\text{CH}_3)_3\text{CF}$ in SbF_5 , respectively. One spectrum, denoted as spectrum I, showed a singlet at δ 4.35, and the other, spectrum II, revealed a doublet at δ 1.30 with a coupling constant $J = 20$ Hz. Which spectrum was obtained from $(\text{CH}_3)_3\text{CF}$ in SbF_5 ?

13-3 Tropylium ion **B** is one of the most stable carbocations. How many π electrons are there in the tropylium ion?

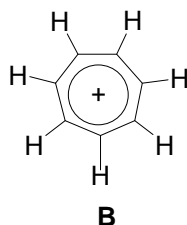

13-4 Is tropylium ion **B** an aromatic structure? Explain.

13-5 The chemical shift of benzene in the ^1H NMR spectrum is δ 7.27. What does the proton NMR spectrum of **B** look like?

- (a) A singlet at δ 9.17.
- (b) A singlet at δ 5.37
- (c) A triplet at δ 9.17.
- (d) A Triplet at δ 5.37.

- 13-6 4-Isopropyltropolone **C** was the first example of a non-benzenoid aromatic compound. It was isolated from cypress trees in Taiwan by Professor T. Nozoe at the National Taiwan University in 1938. Draw resonance structure(s) to illustrate the aromaticity of **C**.

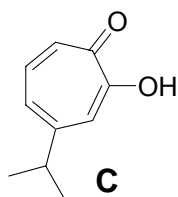

- 13-7 The proton of the OH group in tropolone is acidic. Three moles of tropolone **C** can react with one mole of tris(2,4-pentanedionato)iron(III) ($\text{Fe}(\text{acac})_3$) to form a red complex **D**. What is the structure of **D**?

Problem 14: Photochemical Ring Closure and Opening

1,3,5-Hexatriene is known to undergo light-induced cyclization to give 1,3-cyclohexadiene. The photochemical reaction is reversible and stereospecific. Thus, irradiation of (2*E*,4*Z*,6*E*)-octatriene (**A**) with UV-light gives cyclohexadiene (**B**). The choice of the wavelength of light depends on the absorption maximum of the compound to be irradiated, and the absorption maximum is related to the number of conjugated double bonds in a chain.

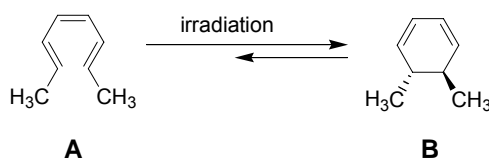

- 14-1 What is the chemical name of the starting triene (**C**) for the related reaction shown below?

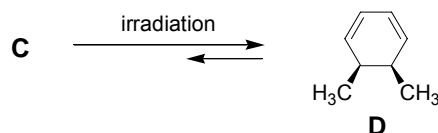

A similar reaction mechanism is involved in the synthesis of biologically active molecules. For example, in the presence of sunlight, 7-dehydrocholesterol (**E**) undergoes an electrocyclic ring opening reaction to give provitamin D_3 (**F**), which can be further transformed through a [1,7]-hydrogen shift to yield vitamin D_3 (**G**).

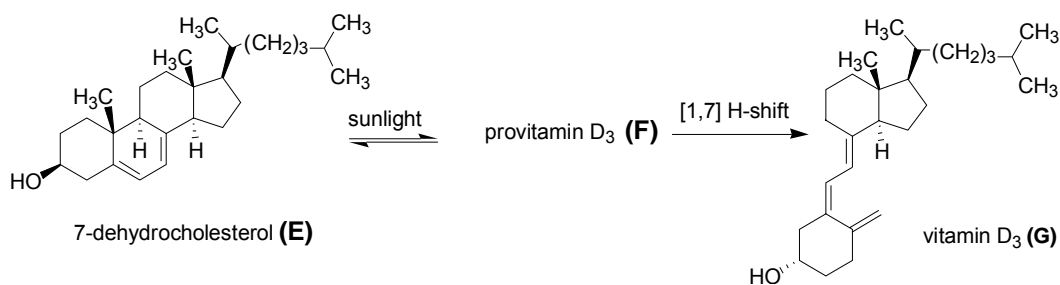

14-2 Of the two compounds 7-dehydrocholesterol (**E**) and vitamin D₃ (**G**), which would you expect to absorb light with the higher energy? (**E** or **G**)

14-3 What is the chemical structure of **F**?

This principle has been elaborated to develop photochromic materials. For example, irradiation of colorless compound **H** with UV light gives colored compound **I**. The color change is reversed upon exposure to visible light.

14-4 Give the structure of colored compound **I**.

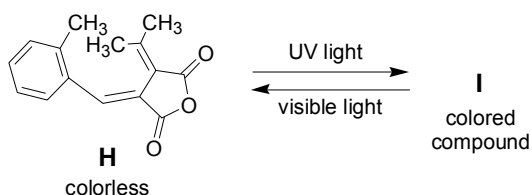

Aromatic hydrocarbons are usually highly fluorescent. However, a neighboring amino substituent may quench the fluorescence. This quenching mechanism is due to Photoinduced Electron Transfer (PET), which can be clearly illustrated by the molecular orbital diagrams shown below. Upon irradiation with a light of suitable wavelength (step 1), the initial aromatic chromophore (state a) will pump an electron from the highest occupied molecular orbital (HOMO) up to the lowest unoccupied molecular orbital (LUMO) (state b). In the presence of a neighboring amino group, one of the lone-pair electrons at the nitrogen atom moves to the HOMO of the excited chromophore (step 2), and thus blocks the normal fluorescent pathway (state c). Coordination of the amine lone-pair electrons to proton or metal ions efficiently inhibits the PET process, and retrieves the fluorescence of the aromatic chromophore (step 3).

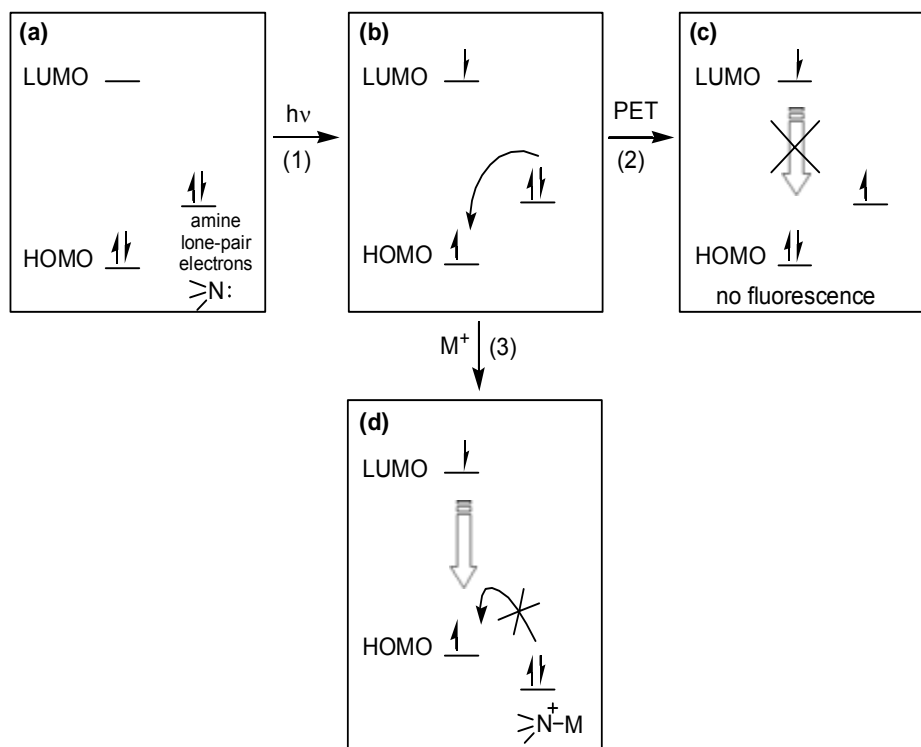

Many interesting and sensitive proton or metal ions fluorescent sensors have been developed based on the manipulation of the PET process. For example, compound **J** is used as a pH-sensor.

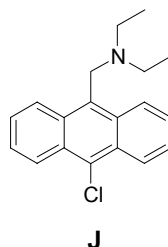

14-5 Do you expect that compound **J** is fluorescent in an alkaline solution (pH = 10.0)?

Problem 15: Stereochemistry

A simple two-dimensional representation for showing the three-dimensional arrangement of groups bonded to a carbon center is called a “*Fischer projection*”. In this molecular representation, the intersection point of two perpendicular lines represents an sp^3 center. The horizontal lines connecting B and D to the central carbon atom represent the bonds that are out of plane relative to the observer. The vertical lines connecting A and C to the central carbon atom

represent the bonds that are directed away from the observer into the plane of the page.

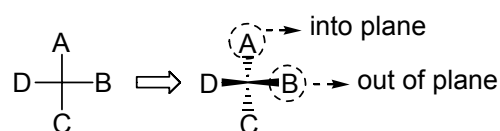

- 15-1 ChiraPhos was developed by Prof. Kagan and has found useful applications in asymmetric synthesis. Using the Fischer projection shown below, assign the absolute configuration of the chiral centers of ChiraPhos in terms of the *R/S* notation according to the Cahn-Ingold-Prelog sequence rule.

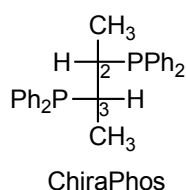

- 15-2 One of the stereoisomers of ChiraPhos is a *meso* compound. What are the identities of **X** and **Y** in the Fischer projection shown below?

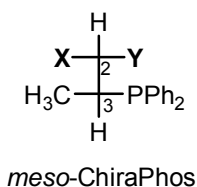

It is very useful and common to use Fischer projections for the stereo representation of carbohydrates. For example, the following Fischer projection represents the structure of D-glucose. It is interesting to note that the open-chain glucose can be interconverted with cyclic structures through the hemiacetal formation between the C₅-OH and the C₁-aldehyde group.

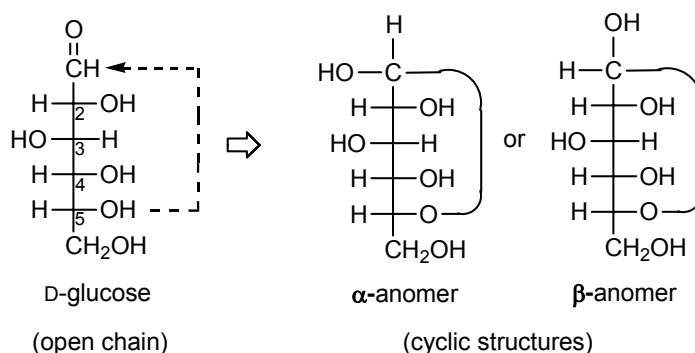

The hemiacetal formation generates two stereoisomers, which are called “*anomers*”. The pure α -anomer of D-glucose has a specific rotation of $+112.2^\circ$, whereas the pure β -anomer has a specific rotation of $+18.7^\circ$. In water, either one of the two anomers gives an equilibrium mixture with a specific rotation of $+52.6^\circ$.

- 15-3 Calculate percentage of α -anomer in the equilibrium mixture of D-glucose in water.

15-4 Which is the more stable anomer in water? (α or β)

15-5 Draw the chair conformation of the β -anomer.

15-6 What is the common intermediate for the interconversion between the α - and β -anomers?

The addition reaction of HCN to an aldehyde generates a cyanohydrin, which can be further reduced to form an α -hydroxyaldehyde.

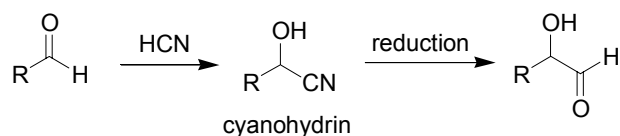

High homologs of carbohydrates, such as D-talose, can be synthesized from D-glyceraldehyde by repeating the same reaction conditions three times as shown below.

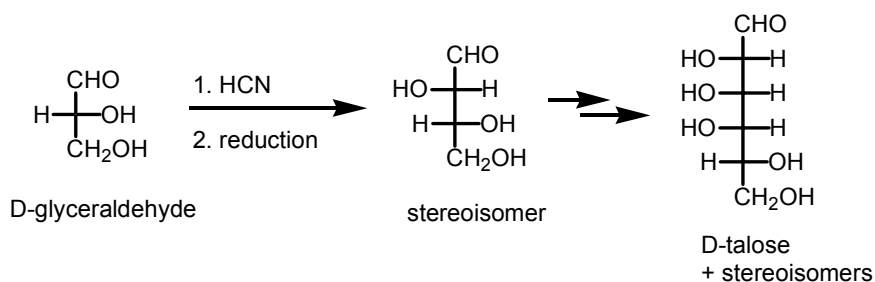

15-7 How many pairs of enantiomers will appear in the final product mixture?

Enzymes are remarkable biological catalysts that control the pattern of chemical transformations in living organisms. Because of their striking catalytic power and specificity, applying enzymes in organic synthesis has become one of the fastest growing areas for the development of new synthetic methodology. Following are the data for the yeast-mediated kinetic resolution of racemic 2-substituted cyclohexanone via Baeyer Villiger reactions (Table 1).

Table 1. Yeast-mediated kinetic resolution of racemic 2-substituted cyclohexanone via Baeyer Villiger reactions

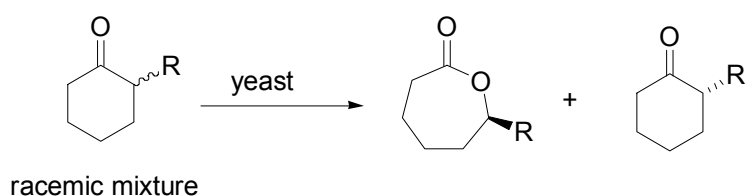



Entry	R	Yield (%)	ee%	Yield (%)	ee%
1	Et	79	95	69	98
2	<i>n</i> -Pr	54	97	66	92
3	Allyl	59	98	58	98

ee: enantiomeric excess

15-8 What is the ratio of (*R*)/(*S*) isomers of 6-allylcaprolactone in entry 3?

15-9 MCPBA (*meta*-chloroperbenzoic acid) is a common oxidizing agent for Baeyer Villiger reactions. Using MCPBA as an oxidizing agent, instead of yeast, for the above reaction, what will be the ee% of the caprolactone product?

Problem 16: Organic Synthesis

One of the primary demands for the development of organic light emitting diodes (OLEDs) is the search for highly efficient luminescent materials which can be either small molecules or polymers. For example, fluorene, a methylene-bridged biphenyl, exhibits a higher quantum yield of fluorescence than biphenyl.

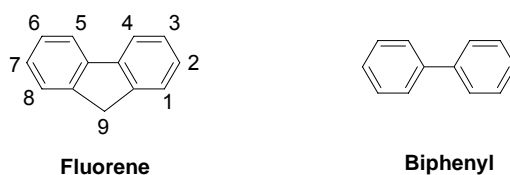

Many fluorene derivatives have been developed that have subsequently found promising applications in flat-panel-display technology. In order to avoid intermolecular interactions, bulky substituents have been introduced at the C9 position of fluorene. One example of this is compound **C**, an interesting and useful building block in the development of a highly efficient blue light emitting material, the synthesis of which is shown in the following scheme.

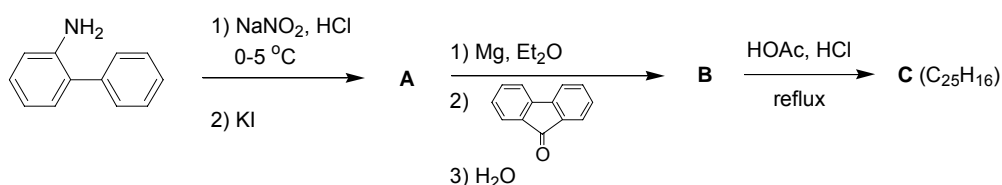

16-1 Draw the structures of **A**, **B**, and **C**.

Liquid crystals have become a part of our daily life, from wristwatches, pocket calculators, to full color flat-panel displays. Liquid crystal molecules usually contain a rigid core with a flexible terminal alkyl chain as shown in the example below.

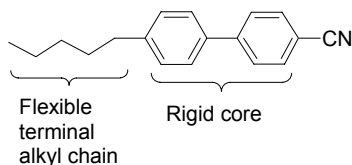

Biphenyl and terphenyl are common basic skeletons for the rigid core of liquid crystals. This kind of structure can be effectively synthesized through palladium catalyzed coupling of an aryl bromide or iodide with arylboronic acid, known as the Suzuki coupling reaction.

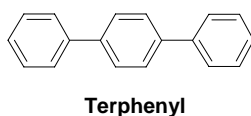

A typical example of a Suzuki coupling reaction is shown below. Bromobenzene reacts with phenylboronic acid in the presence of a palladium catalyst to give biphenyl.

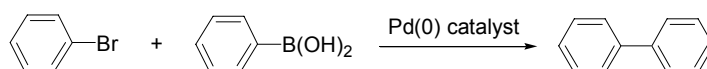

The following is a synthetic scheme for the preparation of two liquid crystal molecules, 4-cyano-4'-pentylbiphenyl and **G**.

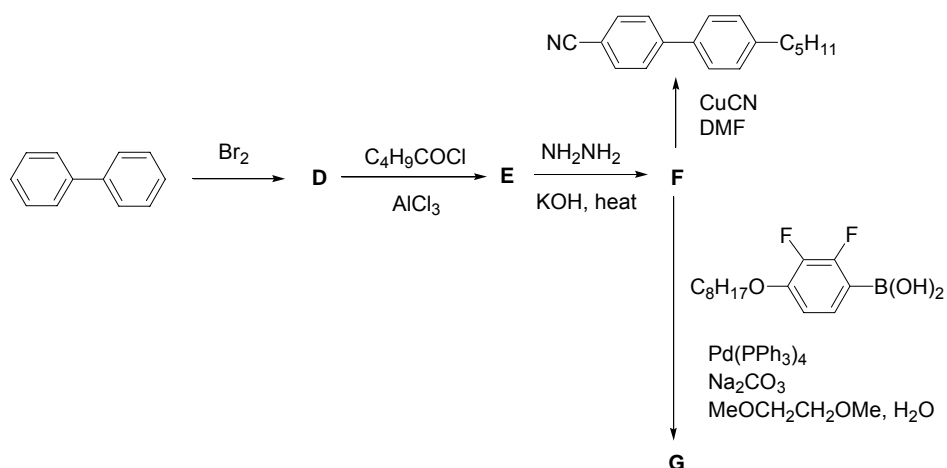

16-2 What are the structures of **D**, **E**, **F**, and **G**?

Problem 17: Spectroscopy and Polymer Chemistry

Organic polymers have had a great impact on our daily lives. Millions of tons of different kinds of polymers are produced every year. Synthetic organic polymers have a variety of uses, from textiles to computer chips, and to the life saving artificial heart valve. They are widely used as plastics, adhesives, engineering materials, biodegradable plastics, and paints. Poly(vinyl alcohol) (PVA) is an important example of a water-soluble polymer. One synthetic route to PVA is summarized in Scheme 1.

Scheme 1



Polymer **B** shown above is also a major component in chewing gum. Elemental analysis of **A** suggests a ratio of C:H:O = 56:7:37. In addition, elemental analysis of **B** gives an almost identical composition of C, H, and O. The following IR and ^1H NMR spectra were recorded for Monomer **A**.

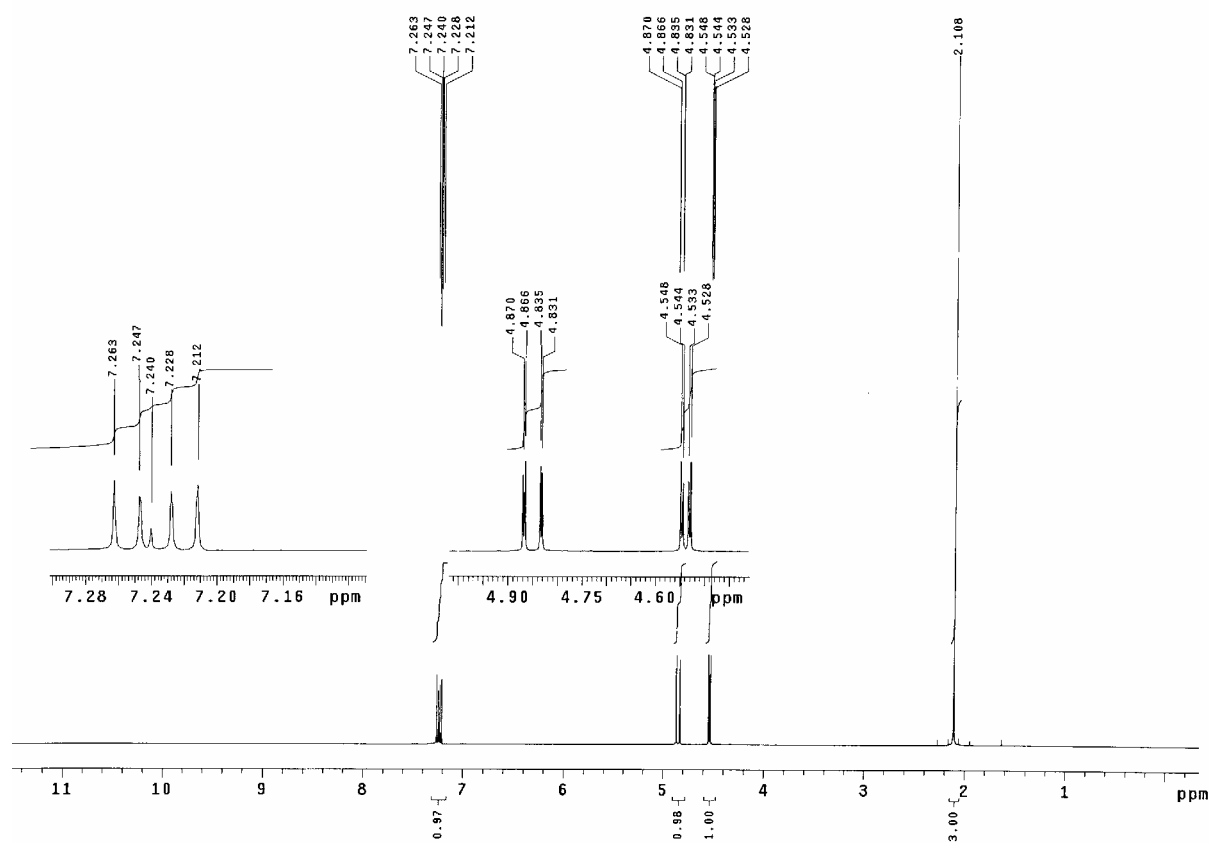

^1H NMR spectrum of Monomer **A**

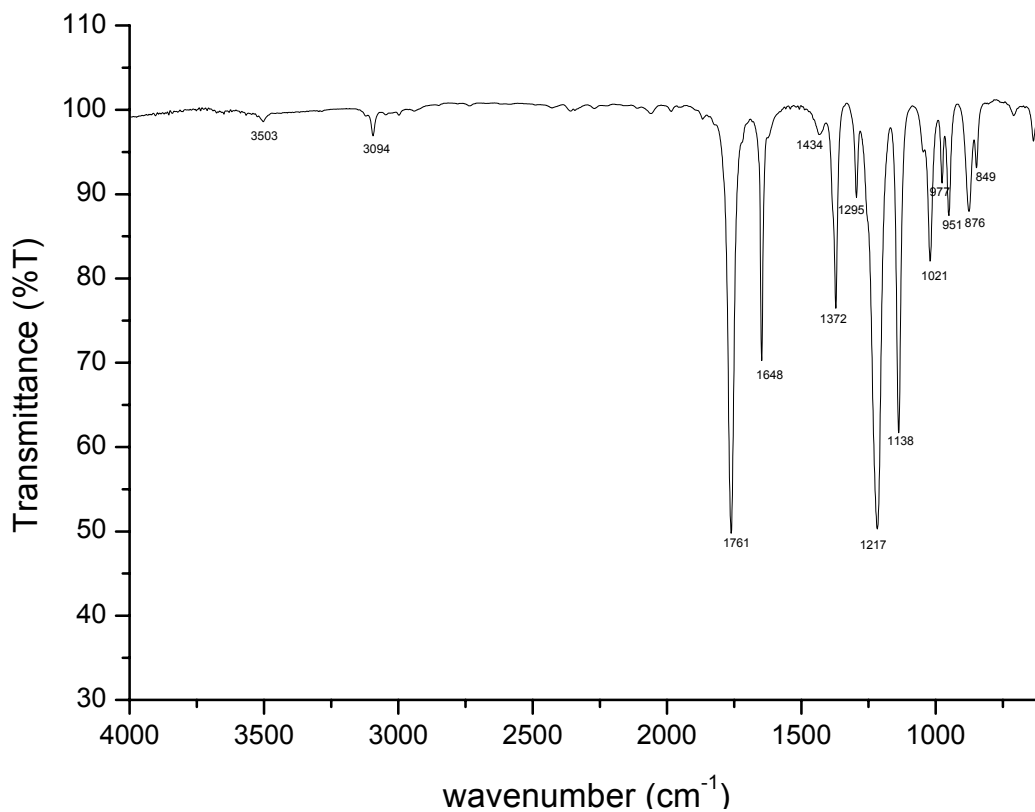

IR Spectrum of Monomer **A**

- 17-1 What is the molecular formula of **A**?
- 17-2 Which functional group would give an IR absorption band at 1761 cm⁻¹?
- 17-3 What is the chemical structure of **A**?
- 17-4 Draw a portion of polymer **B**. Show at least three repeat units.
- 17-5 Provide a method for the transformation of **B** to **PVA**.
- 17-6 How many pairs of enantiomers would be obtained from polymer **B** with a molecular weight of 8600, assuming that the polymer is terminated by hydrogen abstraction and the mass of the terminal groups can be ignored?
- 17-7 Compound **C**, an isomer of **A**, is also an important monomer for the synthesis of polymers. On the basis of its ¹H NMR and IR spectra provided below, deduce the chemical structure of **C**.

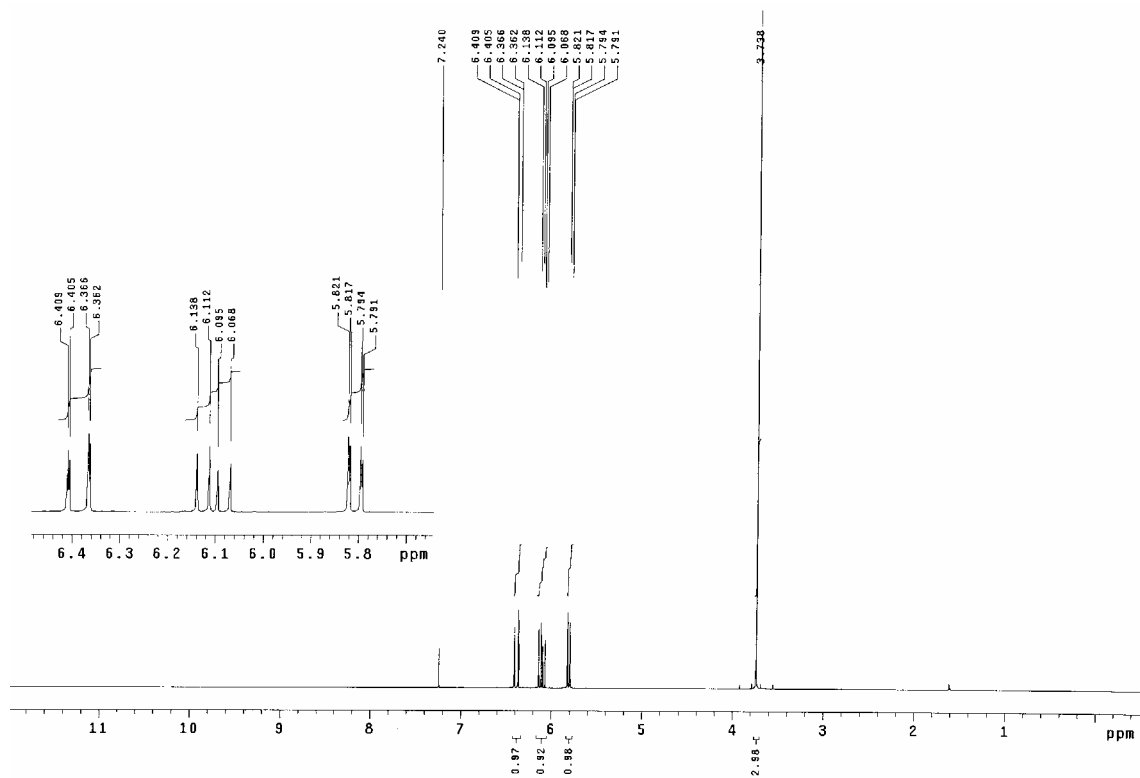

¹H NMR spectrum of Monomer C

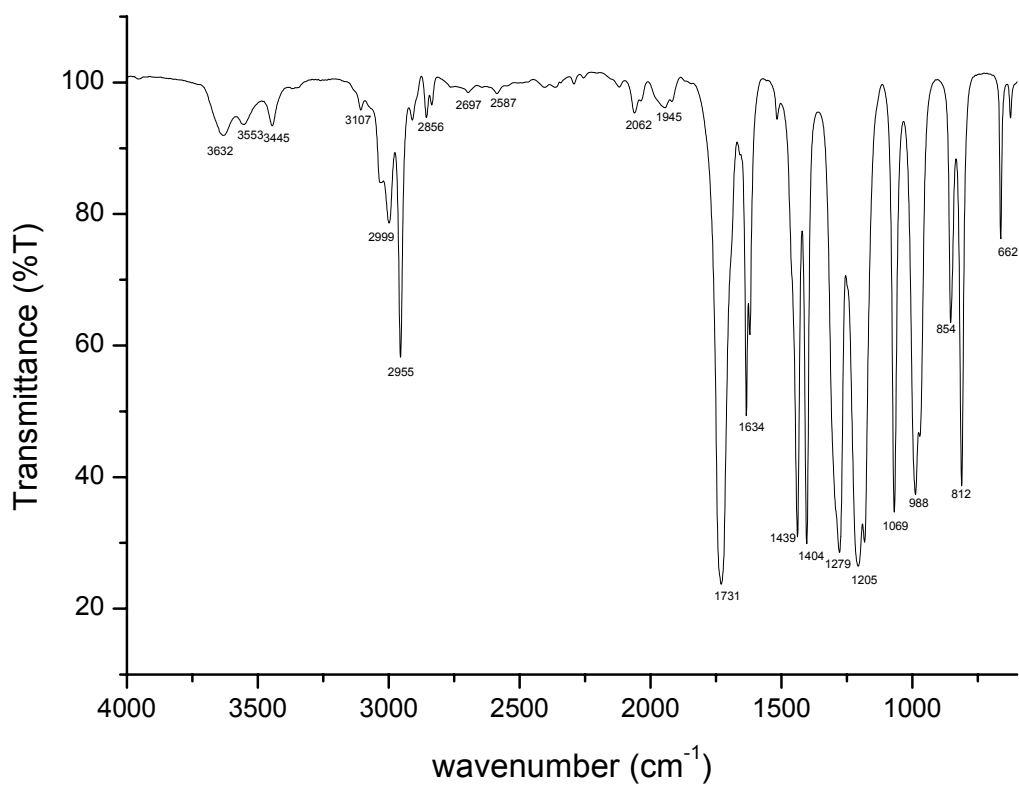

IR Spectrum of Monomer C

Polymer **D** is an acid sensitive macromolecule. On treatment of **D** with a protic acid, gases **E** and **F** are released, and a new polymer **G** is formed. Gas **E** turns an aqueous solution of $\text{Ca}(\text{OH})_2$ into a turbid solution while gas **F** reacts with bromine to give a colorless solution of **H**.

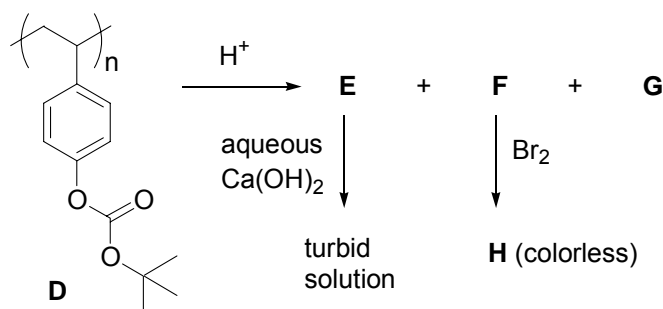

17-8 Draw the chemical structures of **E**, **F**, **G** and **H**?

Polymer **D** has been used to formulate a photo-imaging material by mixing it with a photo acid-generator (PAG). After being coated onto a substrate and exposed to light, protons are generated from the PAG, catalyzing a chemical reaction within the polymer matrix. Sometimes baking after exposure is necessary to accelerate the acid catalyzed reaction. If light is applied through a mask (Figure 1), a latent image of the mask is formed in the polymer matrix. After baking and using an aqueous basic developer to wash away the acidic materials, a patterned substrate **I** is obtained.

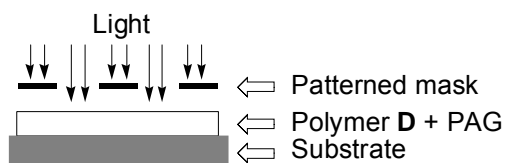

Figure 1

17-9 Which of the following diagrams best illustrates the patterned structure of substrate **I**?



The dark areas represent a polymeric coating that is structurally different from the original one.

Problem 18: Crown Ether and Molecular Recognition

The discovery of crown ethers was made by Charles Pederson in 1967. He was rewarded with a share of the 1987 Nobel Prize for chemistry with Jean-Marie Lehn and Donald Cram for their contributions to supramolecular chemistry.

The following schematic diagram shows a synthetic route to the linear diol **A**. However, because of the presence of catechol in the starting material, the resulting product was a mixture of **A** and the minor product **B**.

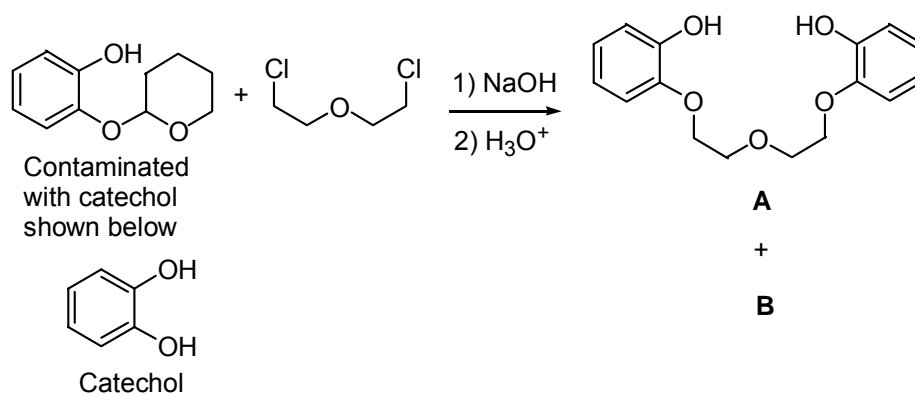

The molecular weight of **B** was found to be 360.1 and it had an elemental composition of C:H:O = 66.5:6.7:26.6. The ¹H NMR spectrum of **B** showed four sets of proton signals. Two of which were observed at δ 7.0-7.5 and the other two at δ 3.7-4.2. The integration ratio of the four sets of signals was 1:1:2:2. Compound **B** strongly binds with the potassium ion. A striking example is the use of **B** to assist the dissolution of KMnO₄ in benzene to give a purple coloration.

18-1 What is the chemical structure of **B**?

18-2 What is the major function of H₃O⁺ in the above reaction?

- (a) To activate ClCH₂CH₂OCH₂CH₂Cl.
- (b) To neutralize NaOH.
- (c) To remove the tetrahydropyran group.
- (d) To act as a buffer to control the pH of the solution.

The following is the synthetic route to [2.2.2]cryptand:

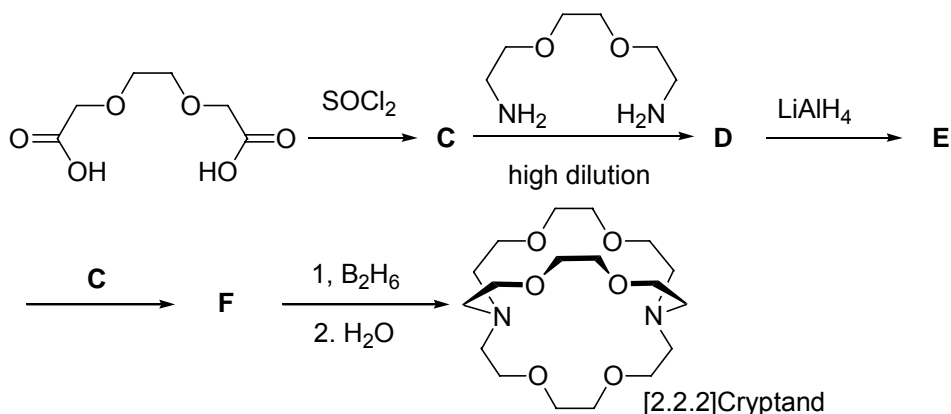

18-3 Draw the structures of **C-F**.

18-4 Why are high dilution conditions required in the synthesis of **D** from **C**?

- Since the reaction between **C** and the diamine is highly exothermic, a high dilution condition is used to dissipate the heat released from the reaction.
- A high dilution condition is employed in order to inhibit oligomer or polymer formation.
- Thermal equilibrium is favored to give **D** in higher yield under high dilution conditions.
- The solubility of the starting material is low.

The affinity of a metal cation is controlled by several factors such as size matching between the host cavity of the crown ether and the guest cation, and the number of donor atoms of the host. Table 1 shows the radii of different alkali metal cations and the diameters of the cavities of several crown ethers.

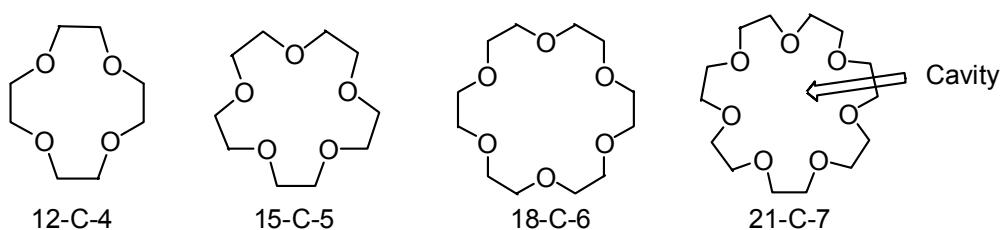

Table 1. Radii of different alkali metal cations and diameters of the cavities of crown ethers.

Cation (radius, pm)	Cavity of the crown ether (diameter, pm)
Li ⁺ (68)	12-C-4 (120-150)
Na ⁺ (98)	15-C-5 (170-220)
K ⁺ (133)	18-C-6 (260-320)
Cs ⁺ (165)	21-C-7 (340-430)

18-5 On the basis of the above data, match the experimental curves **I-III** in Figure 1 with appropriate cyclohexyl crown ethers **G-I**.

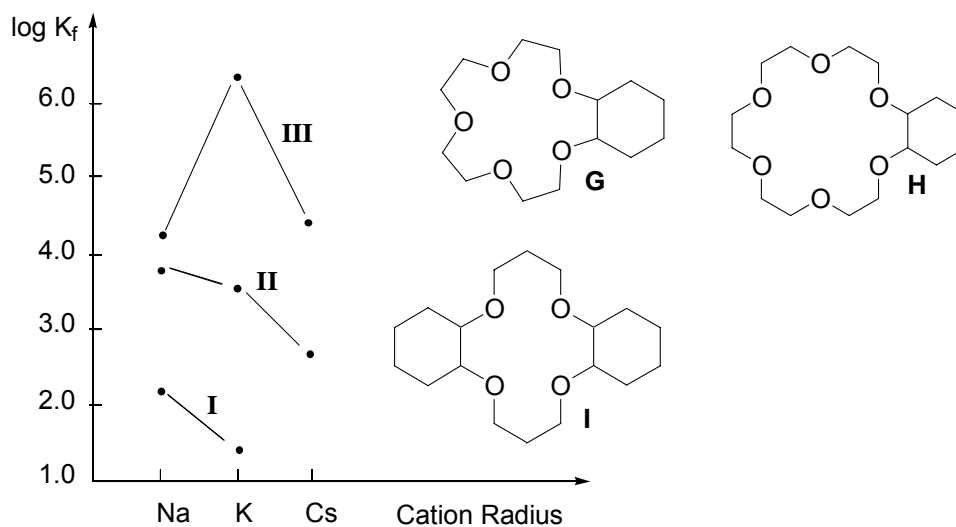
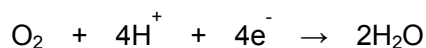

Figure 1. Complexation of Crown Ethers with Cations in Methanol

Problem 19: Enzyme Catalysis

In biological systems, oxidases catalyze the following reaction



The reaction is the key to respiration in living systems. The electrons come from Cytochrome *c*, which contains an iron center. The half reaction is



The extinction coefficients of $\text{Fe}^{\text{II}}\text{cyt } c$ and $\text{Fe}^{\text{III}}\text{cyt } c$ at 550 nm are 27.7 and 9.2 mM cm^{-1} ; respectively.

The absorbance of *cyt c* at 550 nm was observed to decrease at a rate of 0.1 A/sec in a 5 mL solution containing 2.7×10^{-9} M oxidase, and sufficient *cyt c* and oxygen.

19-1 How many moles of *cyt c* were oxidized each second?

19-2 How many moles of oxygen were consumed each second?

19-3 What is the turnover number for oxidase? (Turnover number: the number of product produced by one catalyst per second)

Problem 20: Work in Thermodynamics

Given 10 liters of an ideal gas at 0°C and 10 atm, calculate the final volume and work done, under the following three sets of condition, to a final pressure of 1 atm

20-1 Isothermal reversible expansion

20-2 Adiabatic reversible expansion

20-3 Irreversible adiabatic expansion carried out as follows: Assume the pressure is suddenly released to 1 atm and the gas expands adiabatically at constant pressure.

[Note that the molar heat capacity at constant volume is given by the relation: $\bar{C}_v = \frac{3}{2}R$, where R is the gas constant.]

Problem 21: Kinetics — Atmospheric Chemistry

The following second-order reaction is important in air pollution.

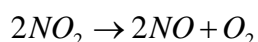

21-1 Derive an integrated relationship between the total pressures in the reaction vessel, originally containing pure NO₂, at the time t.

21-2 It was found that when a 2 liter vessel is filled with NO₂ at a pressure of 600 mm of Hg and a temperature of 600 °C, the reaction is 50% complete after 3 min. Calculate the rate constant.

Problem 22: Kinetics and Thermodynamics

The concept of kinetic versus thermodynamic control of reaction products has frequently been employed in organic synthesis to direct product formation, for example, in sulfonation, Diels-Alder, isomerization and addition reactions. Here the interconversion of two different products can be achieved competitively by controlling the reaction conditions. It is normally represented as a concurrent reaction scheme, as shown below for the case where the reaction of A proceeds competitively toward products B and C.

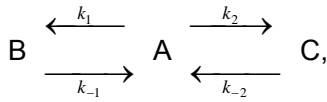

The energy profile for the reaction is depicted in the Figure below.

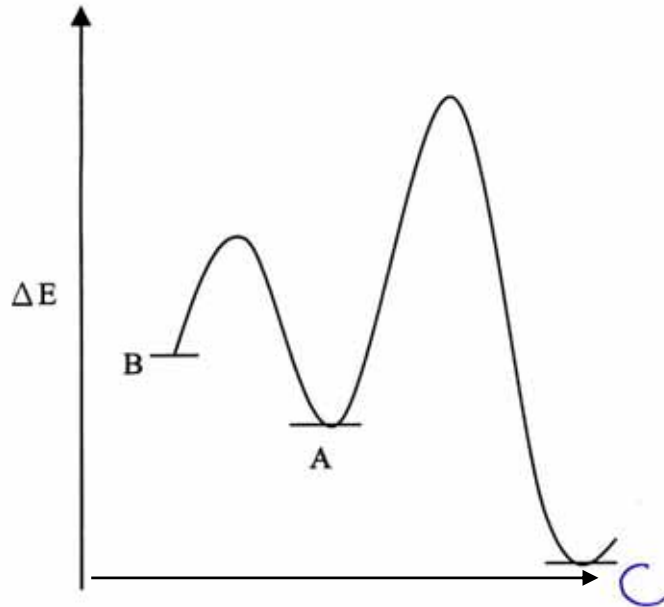

- 22-1 Given the rate constants $k_1=1$, $k_{-1}=0.01$, $k_2=0.1$, and $k_{-2}=0.0005 \text{ min}^{-1}$, estimate the product ratio B/C in the first 4 min of the reaction.
- 22-2 Using the same rate constants, estimate the product ratio B/C when the reaction time exceeds 4 days.
- 22-3 B is called the kinetic-controlled product, while C is called the thermodynamic-controlled product. When the temperature of the system increases, which reaction process is favored?

Problem 23: Phase Diagram

The phase diagram is a convenient way to indicate the phases of a substance as a function of temperature and pressure. Answer the following questions based on the phase diagram of water given below:

- 23-1 What phases are present at A, B, and C?
- 23-2 Why does ice not sink in its own liquid?

- 23-3 When water freezes, it expands. Explain this observation using the Clapeyron equation, which may be expressed by $\frac{dp}{dT} = \frac{\Delta H}{T\Delta V}$. Here, ΔH and ΔV denote the change of molar enthalpy and molar volume of water, respectively.
- 23-4 A glass container partially filled with water is connected to a vacuum pump. What changes will be observed when the pump is turned on?
- 23-5 A man is skating on the surface of a sheet of ice where the air pressure is 1 atm and the temperature is 0 °C. What changes will be observed along the skating track on the surface of the ice, assuming the ice can withstand his weight without cracking?

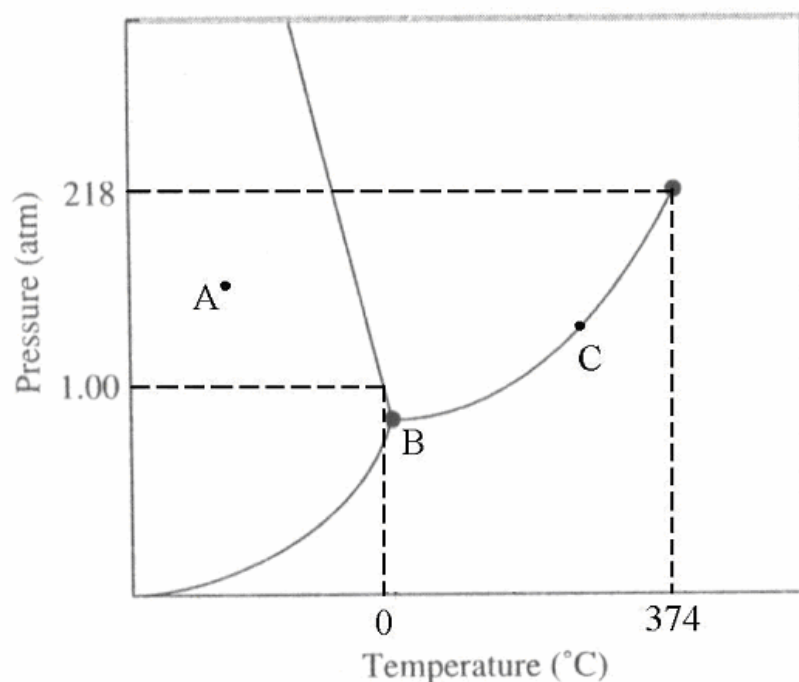

Problem 24: Standard Deviation in One - Dimensional Quantum Mechanics

Some measurable physical quantity, if measured numerically, may lead to an uncertainty which is expressed by a standard deviation, σ . Such a standard deviation is defined as

$$\sigma = \sqrt{\langle G^2 \rangle - \langle G \rangle^2},$$

where G is a measurable physical property; $\langle G \rangle$ is the average value of G ; $\langle G^2 \rangle$ is the average value of G^2 . The average values, $\langle G \rangle$ and $\langle G^2 \rangle$, can be obtained by integrating the corresponding physical quantity multiplied by its probability distribution over all the values of G . This definition may be applied to both classical and quantum mechanical worlds. Two examples related to the estimate of σ , one for the kinetic property of gaseous molecules and the other for the

particle motion in one dimension, are given in the following.

- 24-1 The distribution of speeds of gaseous molecules at a fixed temperature can be described by the following probability density, called the Maxwell-Boltzmann distribution,

$$F(v) = 4\pi v^2 \left(\frac{M}{2\pi RT} \right)^{3/2} \exp\left(\frac{-Mv^2}{2RT} \right)$$

where v is the speed of molecule, M is the mass of molecule, T is the temperature in Kelvin, and R is the gas constant. Calculate the average speed, $\langle v \rangle$, and the standard deviation, σ_v , of the distribution of speeds of the O_2 molecules at 300 K. ($O_2 = 32$ g/mol, $R = 8.31$ J $K^{-1} \text{mol}^{-1}$)

- 24-2 Suppose a particle moving in the x direction has a normalized wavefunction,

$$\varphi = [(1/\sqrt{2\pi}) \exp(-x^2/2)]^{1/2}; \quad -\infty \leq x \leq \infty,$$

Calculate the average position, $\langle x \rangle$, and the standard deviation, σ_x , of the position distribution of the particle after a large number of measurements of x .

- 24-3 In quantum mechanics, momentum for one dimension can be expressed by an operator,

i.e., $p = -\frac{i\hbar}{2\pi} \frac{d}{dx}$, where \hbar is the Planck's constant. Calculate the average momentum,

$\langle p \rangle$, and the standard deviation, σ_p , for the particle with the same wavefunction described in part 2.

- 24-4 Calculate the uncertainty product of position and momentum, $\sigma_x \sigma_p$, for the above quantum mechanical example.

Some useful integrals are given below:

$$\int_0^{\infty} x^{2n} \exp(-ax^2) dx = \frac{1 \cdot 3 \cdot 5 \cdots (2n-1)}{2^{n+1}} \left(\frac{\pi}{a^{2n+1}} \right)^{1/2}$$

$$\int_0^{\infty} x^{2n+1} \exp(-ax^2) dx = \frac{n!}{2a^{n+1}} \quad \text{where } n = 0, 1, 2, 3, \dots$$

Problem 25: A Particle in a 2-D Box Quantum Mechanics

The π electrons of the iron-heme of a hemoglobin molecule can be visualized as a system of free electrons moving in a two-dimensional box. According to this model, the energy of the electron is

limited to the values

$$E_{n_x, n_y} = \frac{h^2}{8m_e L^2} (n_x^2 + n_y^2), \quad n_x, n_y = 1, 2, 3, \dots$$

where $h=6.63 \times 10^{-34}$ J s is the Planck constant; n_x and n_y are the principal quantum numbers; $m_e=9.11 \times 10^{-31}$ kg is the electron mass; L is the length of the box.

- 25-1 Construct an energy level diagram showing the relative ordering of the lowest 17 orbitals.
- 25-2 Given the molecule contains 26 electrons, determine the electron population of the highest occupied orbitals in the ground state.
- 25-3 Assuming Hund's rule can be applied to this system, predict whether or not this system is paramagnetic.
- 25-4 Light is absorbed only when the condition $h\nu = \Delta E$ is satisfied. If the length L for this 2D box is 1 nm, what is the longest wavelength of light that can lead to excitation? Express your result in nm. [The speed of light, $c = 3.00 \times 10^8$ m/s]

Problem 26: Spectral Analyzer

The configuration of the distributed feedback dye laser (DFDL) system is shown in Fig. 1, and consists of an oscillator and a preamplifier.

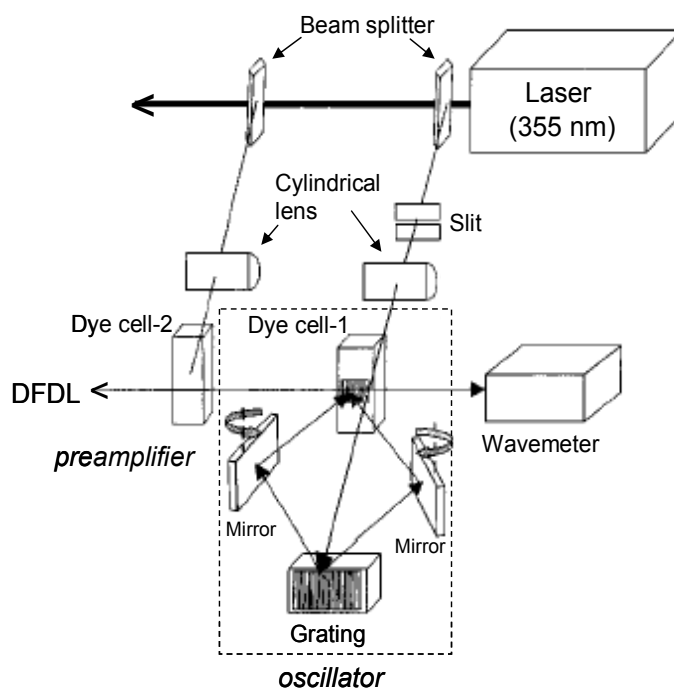

Fig. 1. Block diagram of the distributed-feedback dye laser.

The oscillator is made of a quartz cuvette (dye cell-1) equipped with a dye circulation pump. The detailed construction of the oscillator is shown in Fig. 2.

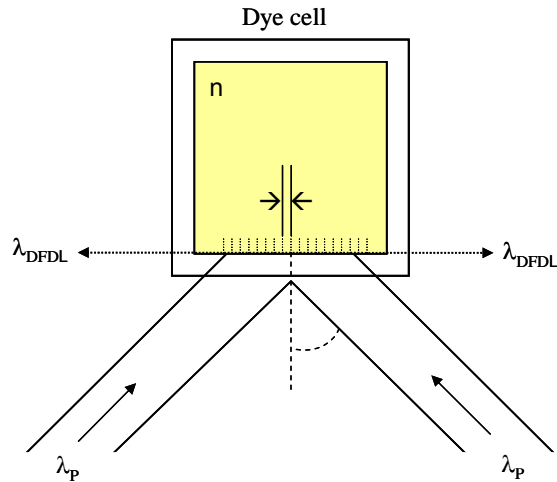

Fig. 2. The detailed construction of a DFDL oscillator

Two laser beams ($\lambda_p = 355.00 \text{ nm}$) are reflected by two rotating dielectric mirrors and subsequently focused onto the dye solution to form an interference pattern, the spacing of which determines the wavelength of the laser emission. The wavelength of the laser emission, λ_{DFDL} , can be calculated using the following equations:

$$\lambda_{DFDL} = 2n\Lambda$$

$$\Lambda = \lambda_p / 2 \sin \theta$$

where n is the refractive index of the medium; Λ , the fringe spacing; and θ , the angle from the normal surface. The laser wavelength can also be determined from the fringe spacing, which, in turn, can be determined from the angle of incidence of the pump beam. The DFDL beams come from two sides of the cell. The wavelength of the DFDL can be measured by a Wavemeter. The power of the DFDL can also be amplified by passing it through a preamplifier (the second dye cell; dye cell-2).

- 26-1 What would be the wavelength of the DFDL when the angle of θ is 60.00° and the refractive index of the medium is 1.40?
- (a) 374 nm
 - (b) 474 nm
 - (c) 574 nm
 - (d) 674 nm
 - (e) 774 nm

Problem 27: Time-of-Flight Mass Spectrometer

There are numerous ways in which we may separate and select ions in a mass spectrometer. Magnetic and electric fields, as well as radio frequency are often used to separate ions in mass spectrometers. The time-of-flight (TOF) mass spectrometer is the simplest type of common mass analyser and it has a very high sensitivity. With the introduction of matrix-assisted laser desorption / ionization (MALDI) or electrospray ionization (ESI), which is used to introduce and ionize macromolecules such as proteins, DNA, and polymers, the measurement of a large mass range became achievable. It is now possible to desorb and analyze ions with molecular weights upwards of one million atomic mass units (amu; $1 \text{ amu} = 1.6605 \times 10^{-27} \text{ kg}$). In general, the sample ions are generated in a source zone of the instrument, by whatever ionization method is being employed. A high voltage (HV) potential is applied across the source to extract and accelerate the ions from the source into the field-free "drift" zone of the instrument. The fundamental operating principle of TOF is that ions of the same kinetic energy will move with different velocities depending on their m/z value. This can be seen in the following equation, the classical equation for kinetic energy.

$$\text{KE} = \frac{1}{2} m v^2$$

This relationship may be rearranged to give velocity in terms of kinetic energy and m/z .

$$v = (2 \cdot \text{KE}/m)^{1/2}$$

If the distance from the point of ion formation to the detector at some fixed point is L (neglecting the extraction time from the source), the time of flight (t) can be calculated by the following equation:

$$t = L / v = L / (2 \cdot \text{KE}/m)^{1/2}$$

In most modern TOF mass spectrometer, ions are generally accelerated to kilo-electron volt (keV) energies. At these energies, flight times will be in the range of a few tens to a few hundreds of microseconds (μs) (depending on the flight distance). The kinetic energy of an ion accelerated by a potential is given by:

$$\text{KE} = zeV$$

Where z is the number of charges on the ion, e is the fundamental unit of charge ($1.6022 \times 10^{-19} \text{ C}$) and V is the applied accelerating potential in volts.

27-1 An average protonated cytochrome has a molecular weight of 12,361 amu. What will be the velocity of the (MH^+) ion of the cytochrome when accelerated by a potential of 20,000 volts?

(a) 18000 m/s

(b) 28000 m/s

(c) 38000 m/s

(d) 48000 m/s

(e) 58000 m/s

27-2 If the detector is positioned 1.00 m from the point of ion formation, the time of flight for the ion will be approximately:

(a) 40 μs

(b) 50 μs

(c) 60 μs

(d) 70 μs

(e) 80 μs

Safety Rules for Students in the Laboratory

All students of chemistry must recognize that hazardous materials cannot be completely avoided. Chemists must learn to handle all materials in an appropriate fashion. While it is not expected that all students participating in the International Chemistry Olympiad know the hazards of every chemical, the organizers of the competition will assume that all participating students know the basic safety procedures. For example, the organizers will assume that students know that eating, drinking or smoking in the laboratory or tasting a chemical is strictly forbidden.

In addition to the common-sense safety considerations to which students should have been previously exposed, some specific rules, listed below, must also be followed during the Olympiad. If any question arises concerning safety procedures during the practical exam, the student should not hesitate to ask the nearest supervisor for direction.

Rules regarding personal protection

1. Eye protection must be worn in the laboratories at all times. If the student wears contact lenses, full protection goggles must also be worn. Eye protection will be provided by the host country.
2. A laboratory coat is required. Each student will bring this item for himself/herself.
3. Long pants and closed-toed shoes are recommended for individual safety. Long hair and loose clothing should be confined.
4. Pipetting by mouth is strictly forbidden. Each student must be provided with a pipette bulb or pipette filler.

Rules for Handling Materials

1. Specific instructions for handling hazardous materials will be included by the host country in the procedures of the practical exam. All potentially dangerous materials will be labelled using the international symbols below. Each student is responsible for recognizing these symbols and knowing their meaning.
2. Do not indiscriminately dispose of chemicals in the sink. Follow all disposal rules provided by the host country.

Safety Rules and Recommendations for the Host Country of the International Chemistry Olympiad

Certainly it can be assumed that all students participating in the IChO have at least modest experience with safety laboratory procedures. However, it is the responsibility of the International Jury and the organizing country to be sure that the welfare of the students is carefully considered. Reference to the Safety Rules for Students in the Laboratory will show that the students carry some of the burden for their own safety. Other safety matters will vary from year to year, depending on practical tasks. The organizers of these tasks for the host country are therefore assigned responsibility in the areas listed below. The organizers are advised to carefully test the practical tasks in advance to ensure the safety of the experiments. This can best be accomplished by having students of ability similar to that of IChO participants carry out the testing.

Rules for the Host Country

1. Emergency first-aid treatment should be available during the practical examination.
2. Students must be informed about the proper methods of handling hazardous materials.
 - a) Specific techniques for handling each hazardous substance should be included in the written instructions of the practical examination.
 - b) All bottles (containers) containing hazardous substances must be appropriately labelled using international symbols.

3. Chemical disposal instructions should be provided to the students within the written instructions of the practical examination. Waste collection containers should be used for the chemicals considered dangerous to the environment.
4. The practical tasks should be designed for appropriate (in other words, minimum) quantities of materials.
5. The laboratory facilities should be chosen with the following in mind:
 - a) Each student should not only have adequate space in which to work, but should be a safe distance from other students.
 - b) There should be adequate ventilation in the rooms and a sufficient number of hoods when needed.
 - c) There should be more than one emergency exit for each room.
 - d) Fire extinguishers should be near by.
 - e) Electrical equipment should be situated in an appropriate spot and be of a safe nature.
 - f) There should be appropriate equipment available for the clean-up of a spill.
6. It is recommended that one supervisor be available for every four students in the laboratory to adequately ensure safe conditions.
7. The organizers should follow international guidelines for the use of toxic, hazardous or carcinogenic substances in the IChO.

Hazard Warning Symbols and Hazard Designations and their Explanation (Applied to Chemicals in Schools)

1. Explosive substances (E)

These are substances which can be caused to explode by exposure to a flame or which are more sensitive to impact or friction than 1,3-Dinitrobenzen (e.g. picrates, organic peroxides). In particular they include substances with R-ratings R 1 - R 3, designation E.

When using and storing these substances, the S-provisions (S 15 - S 17) must be observed.

2. Fire-inducing substances, Oxidizing (O)

These are substances which can have a strong exothermic reaction on coming into contact with other, particularly flammable substances or organic peroxides. They include in particular substances R 7 to R 9, designation O.

3. Highly flammable, easily flammable and flammable substances (F +, F)

In liquid form, highly flammable substances have an ignition point below 0°C and a boiling point of 35°C maximum. They are to be designated by the danger symbol F+ and the rating R 12.

Substances are easily flammable if they:

- a) can heat up and ignite at normal air temperature without energy supply,
- b) are easily ignited in the solid state by short exposure to a source of flammation and continue to burn or glow after removal of the latter,
- c) ignite below 21°C in the liquid state,
- d) ignite in the gaseous state if mixed with air at 101,3 kPa and 20°C,
- e) develop easily flammable gases in dangerous quantities when in contact with water or damp air, and
- f) ignite if brought into contact with air when in a dustlike state.

These substances are to be designated with the danger symbol F and the rating R 11.

Flammable substances have in liquid form an ignition point of 21°C to 55°C and are to designated with the rating R 10, no danger symbol.

When dealing with highly flammable, easily flammable and flammable liquids, they may only be heated using sealed electrical heating equipment which is not in itself a source of flammation. All substances must be heated in such a way that the dangerous vapours liberated by heating cannot escape into the atmosphere. This does not apply to fire-hazardous substances in small quantities for fire demonstrations.

The regulations laid down by the state fire authorities must be observed.

4. Toxic substances (T+, T, X_n)

Legislation applying to chemicals distinguishes three categories of toxicants:

- highly toxic substances (R 26 - R 28), danger symbol T+,
- toxic substances (R 23 - R 25), danger symbol T,
- less toxic substances (R 20 - R 22), danger symbol X_n.

Highly toxic substances are those which can cause grave acute or chronic health damage or death almost immediately if inhaled, swallowed or absorbed through the skin in small amounts.

Toxic substances are those which can cause considerable acute or chronic health damage or death if inhaled, swallowed or absorbed through the skin in small amounts.

Less toxic substances (noxious substances) are those which can cause restricted health damage if inhaled, swallowed or absorbed through the skin.

If highly toxic or toxic substances are produced in the course of an experiment (e.g. chlorine, hydrogen sulfide), these may only be produced in the quantities necessary for the experiment. In the case of volatile substances, the experiment must be conducted under a hood where the gas can be drawn off. Residues must be appropriately disposed of after the experiment and may on no account be stored. If the facilities for disposal are not available, the experiment may not be conducted.

Less toxic substances and preparations may be obtained without a permit. Less toxic substances are also those which contain a highly toxic or toxic substance at a level of concentration below that determined by law as the maximum for classification as noxious. Chlorine water, bromine water and hydrogen sulfide solution in a concentration of up to 1% may therefore be used under instruction.

5. Corrosives and irritants (C, X_i)

Caustic or corrosive substances (R 34, R 35), designation C, are those which can destroy living materials by their action upon it. Substances are classed as irritants (R 36 - R 38), designation X_i, if they cause inflammation - without being corrosive - on direct, prolonged or repeated contact with the skin or mucous membranes. The relevant safety recommendations (S 22 - S 28) should be observed.

6. Carcinogenic, genotype or embryo-damaging, chronically harmful substances

Substances may not be used for instruction if they have a proven carcinogenic effect (R 45), if they cause hereditary damage (R 46) or embryo damage (R 47), or if they are chronically damaging (R 48), particularly those substances classed as unmistakably carcinogenic. Such substances must be removed from all school stocks. Storage is not permitted under any circumstances.

Further, substances for which there is a well-founded suspicion of carcinogenic potential (R 40) may only be used if corresponding safety precautions are taken and only in such cases where they cannot be replaced by less dangerous chemicals.

R-Ratings and S-Provisions

Nature of Special Risks (R)

- R 1 Explosive when dry.
- R 2 Risk of explosion by shock, friction, fire or other sources of ignition.
- R 3 Extreme risk of explosion by shock, friction, fire or other sources of ignition.
- R 4 Forms very sensitive explosive metallic compounds.
- R 5 Heating may cause an explosion.
- R 6 Explosive with or without contact with air.
- R 7 May cause fire.
- R 8 Contact with combustible material may cause fire.
- R 9 Explosive when mixed with combustible material.
- R 10 Flammable.
- R 11 Highly flammable.
- R 12 Extremely flammable.
- R 13 Extremely flammable liquefied gas.
- R 14 Reacts violently with water.
- R 15 Contact with water liberates highly flammable gases.
- R 16 Explosive when mixed with oxidizing substances.
- R 17 Spontaneously flammable in air.
- R 18 In use, may form flammable/explosive vapour-air mixture.
- R 19 May form explosive peroxides.
- R 20 Harmful by inhalation.
- R 21 Harmful in contact with skin.
- R 22 Harmful if swallowed.
- R 23 Toxic by inhalation.
- R 24 Toxic in contact with skin.
- R 25 Toxic if swallowed.
- R 26 Very toxic by inhalation.
- R 27 Very toxic in contact with skin.
- R 28 Very toxic if swallowed.
- R 29 Contact with water liberates toxic gas.
- R 30 Can become highly flammable in use.
- R 31 Contact with acids liberates toxic gas.
- R 32 Contact with acids liberates very toxic gas.
- R 33 Danger of cumulative effects.
- R 34 Causes burns.
- R 35 Causes severe burns.
- R 36 Irritating to eyes.
- R 37 Irritating to respiratory system.
- R 38 Irritating to skin.

- R 39 Danger of very serious irreversible effects.
- R 40 Possible risks of irreversible effects.
- R 41 Danger of serious eye damage.
- R 42 May cause sensitization by inhalation.
- R 43 May cause sensitization by skin contact.
- R 44 Risk of explosion if heated by occlusion.
- R 45 May cause cancer.
- R 46 May cause hereditary damage.
- R 47 May cause embryo damage.
- R 48 Danger of chronic damage.

Safety Advice (S)

- S 1 Keep locked up.
- S 2 Keep out of reach of children.
- S 3 Keep in a cool place.
- S 4 Keep away from living quarters.
- S 5 Keep contents under (appropriate liquid to be specified by the manufacturer).
- S 6 Keep under (inert gas to be specified by the manufacturer).
- S 7 Keep container tightly closed.
- S 8 Keep container dry.
- S 9 Keep container in a well-ventilated place.
- S 10 Keep contents wet.
- S 11 Avoid contact with air.
- S 12 Do not keep the container sealed.
- S 13 Keep away from food, drink and animal feeding stuffs.
- S 14 Keep away from (incompatible materials to be indicated by the manufacturer).
- S 15 Keep away from heat.
- S 16 Keep away from sources of ignition - No smoking.
- S 17 Keep away from combustible materials.
- S 18 Handle and open container with care.
- S 20 When using do not eat or drink.
- S 21 When using do not smoke.
- S 22 Do not inhale dust.
- S 23 Do not inhale gas/fumes/vapour/spray.
- S 24 Avoid contact with skin.
- S 25 Avoid contact with eyes.
- S 26 In case of contact with eyes, rinse immediately with plenty of water and seek medical advice.
- S 27 Take off immediately all contaminated clothing.
- S 28 After contact with skin, wash immediately with plenty of (to be specified by the

manufacturer).

- S 29 Do not empty into drains.
- S 30 Never add water to this product.
- S 31 Keep away from explosive materials.
- S 33 Take precautionary measures against static discharges.
- S 34 Avoid shock and friction.
- S 35 This material and its container must be disposed of in a safe way.
- S 36 Wear suitable protective clothing.
- S 37 Wear suitable gloves.
- S 38 In case of insufficient ventilation, wear suitable respiratory equipment.
- S 39 Wear eye/face protection.
- S 40 To clean the floor and all objects contaminated by this material, use (to be specified by the manufacturer).
- S 41 In case of fire and/or explosion do not breathe fumes.
- S 42 During fumigation/spraying wear suitable respiratory equipment.
- S 43 In case of fire, use (indicate in space the precise type of fire-fighting equipment. If water increases the risk, add - Never use water).
- S 44 If you feel unwell, seek medical advice (show the label where possible).
- S 45 In case of accident or if you feel unwell, seek medical advice (show the label where possible).

Problem 28: Identification of Unknown Solid Samples

There are 12 unknown solid samples in vials numbered A01 to A12 on your table. Each vial contains about 100 mg of crystals or powder of one pure compound. The unknown samples are as following:

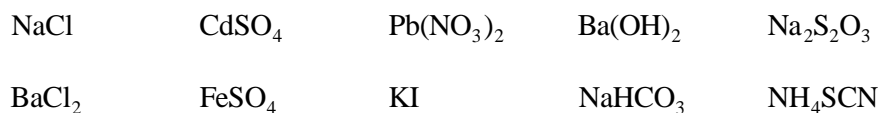

Note: (1) There are two duplicated unknown samples.

(2) The hydrated H₂O of crystal is omitted in the formulas listed above.

On your table, there are also 14 empty droppers, 12 empty vials, 12 coffee stirrers, and 5 droppers containing the following reagents:

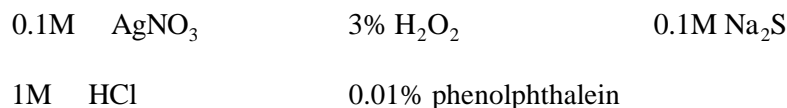

Procedure:

1. Use the coffee stirrers provided to transfer about 20 mg of each unknown sample into separate empty vial, add about 1 mL of distilled water to each vial to make the unknown solutions and label them appropriately.
2. Use the five reagents provided and mutual reactions between the unknown solutions to identify each unknown sample.

Note: (1) This practical exercise is a kind of spot test. You can do it on the provided pallet or on a sheet of white paper.

(2) Be sure to confirm your observations before writing your answers in the blanks of the Data Sheet.

Data Sheet 28

<u>Compound</u>	<u>Code</u>	<u>Compound</u>	<u>Code</u>	<u>Compound</u>	<u>Code</u>
KI	_____	BaCl ₂	_____	Na ₂ S ₂ O ₃	_____
NaCl	_____	FeSO ₄	_____	NH ₄ SCN	_____
Pb(NO ₃) ₂	_____	CdSO ₄	_____	NaHCO ₃	_____
Ba(OH) ₂	_____				

Problem 29: Identification of Unknown Solutions (I) – Spot Test without Electrolysis

- 1 This is a practical exercise best performed using spot test.
- 2 In a plastic bag, there are 12 unknown samples in droppers numbered X01 to X12. Each sample in the 1 mL droppers, contains a 0.1 M aqueous solution of a simple compound. A list of the compounds is given in the Data Sheet. There are also a dropper containing phenolphthalein, two empty droppers, a pallet, two coffee stirrers, a bottle of distilled water, and a small pack of tissue paper for your use.
- 3 Use the materials provided and mutual reactions of the unknown solution to identify each unknown sample and write your answer (code number) in the blank of the Data Sheet.

Note: (1) Three samples are duplicated.

(2) The volume of each sample is about 0.6 mL. No more solution will be provided.

(3) Each correct answer gets 8 points, and each incorrect answer will be penalized 2 points.

Data Sheet 29

<u>Compound</u>	<u>Number</u>	<u>Compound</u>	<u>Number</u>	<u>Compound</u>	<u>Number</u>
NaCl	_____	AgNO ₃	_____	KI	_____
HCl	_____	Pb(NO ₃) ₂	_____	BaCl ₂	_____
H ₂ SO ₄	_____	Na ₂ CO ₃	_____	NaOH	_____

Questions

29-1 How to find out the unknown sample of H₂SO₄ in this work?

29-2 How to confirm the H₂SO₄ solution in this work?

Problem 30: Identification of Unknown Solutions (II) – Spot Test with Electrolysis

Reagents and Equipment

Acid-base indicator	1	Simple electrolysis apparatus	1
Bromothymol Blue	1	Coffee stirrer	2
Distilled water	1	Tissue paper	1
Unknown samples	10		

- 1 Ten unknown samples are shown in the Data Sheet.
- 2 Simple electrolysis apparatus is shown in Fig 1.
- 3 Identify 10 unknown samples (code number: X01 ~ X10)

Note: (1) The compounds in the unknown solutions are given in the Data Sheet.

- (2) Each unknown sample contains only one compound.
- (3) The concentration of each unknown solution is about 0.1 mol/L.
- (4) Write your answers (code number) in the blanks of your Data Sheet.

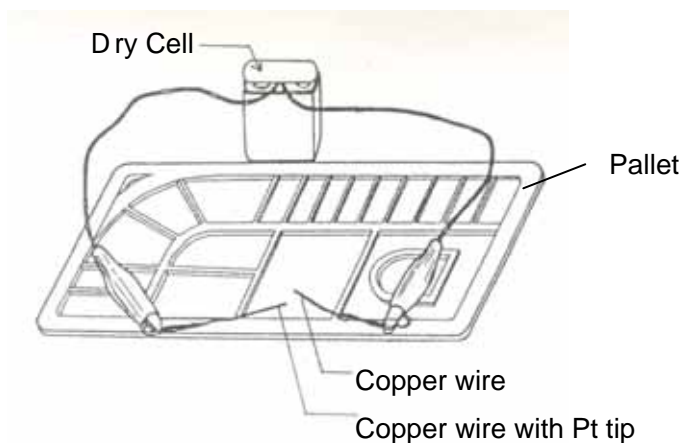

Fig 1. Simple Electrolysis Apparatus

Data Sheet 30

<u>Compound</u>	<u>Number</u>	<u>Compound</u>	<u>Number</u>	<u>Compound</u>	<u>Number</u>
$\text{Cd}(\text{NO}_3)_2$	_____	Na_2S	_____	H_2SO_4	_____
KI	_____	$\text{Pb}(\text{NO}_3)_2$	_____	NaOH	_____
$\text{Na}_2\text{S}_2\text{O}_3$	_____	HCl	_____	$\text{Zn}(\text{NO}_3)_2$	_____
NaCl	_____				

Problem 31: Quantitative Analysis of Ascorbic Acid in a Vitamin C Tablet

The major ingredient in commercial vitamin C is ascorbic acid ($\text{H}_2\text{C}_6\text{H}_6\text{O}_7$, FW = 176.12). It is acidic and a reductant, therefore, both acid-base and redox titrations can be used to measure the amount of ascorbic acid in commercial vitamin C tablets.

This experiment has two parts, the first part involves using an acid-base titration to determine the amount of ascribed acid in a vitamin C tablet. The second part involves using a redox titration to perform a similar determination.

The evaluation is based on accuracy. The acid-base titration accounts for 30%; the redox titration 60%; and a comparison of these two methods 10% of the final score.

CHECK REAGENTS AND APPARATUS BEFORE YOU START

Reagents	Apparatus	
NaOH Solution (concentration is shown on the label)	Graduated Cylinder 10 mL	x 1
	100 mL	x 1
Thiosulfate (Na ₂ S ₂ O ₃) Solution (concentration is shown on the label)	Beaker 100 mL	x 2
	250 mL	x 2
Iodine Solution (0.01 M)		
Indicator	Erlenmeyer 125 mL	x 4
	250 mL	x 2
Phenolphthalein Solution		
Methyl Red Solution	Filter Paper	x 10
	Weighing Paper	x 10
Starch Solution	Mold and Pastel	1 set
	Buret (1 rack)	x 2
	Buret Brush	x 1
	Volumetric Flask, 100 mL	x 1
	Spatula	x 1
	Funnel	x 1
	Pipette (20 mL) / Safety Bulb	1 set
	Pasteur Pipette (dropper)	x 6
	Brush	x 1

Procedure:

Dissolve the vitamin C tablet in water; filter if necessary. The final volume of the solution should be 100 mL.

Part 1: Acid-Base Titration

1-1 Pipette 10 mL of the above solution into an Erlenmeyer flask. Choose the appropriate indicator to perform titration.

1-2 Repeat step 2 a total of 3 times.

Part 2: Redox Titration

2-1 Determination of the concentration of the provided iodine solution using the standardized thiosulfate solution.

2-1-1 Pipette 20 mL of the iodine solution into an Erlenmeyer flask, and titrate by using standard $\text{Na}_2\text{S}_2\text{O}_3$ solution. Use starch as the indicator.

2-1-2 Repeat step 4 a total of 3 times.

2-2 Determination of the amount of ascorbic acid

2-2-1 Pipette 10 mL of the solution from step 1 into an Erlenmeyer flask. Add a few drops of starch as indicator and titrate with the iodine solution.

2-2-2 Repeat step 6 a total of 3 times.

Data Sheet 31

31-1 Acid-Base Titration

First titration Vitamin C solution _____mL; NaOH solution used _____mL

Second titration Vitamin C solution _____mL; NaOH solution used _____mL

Third titration Vitamin C solution _____mL; NaOH solution used _____mL

31-2 Redox Titration

31-2-1 Iodine concentration determination

First titration Iodine solution _____mL; $\text{Na}_2\text{S}_2\text{O}_3$ solution used _____mL

Second titration Iodine solution _____mL; $\text{Na}_2\text{S}_2\text{O}_3$ solution used _____mL

Third titration Iodine solution _____ mL; Na₂S₂O₃ solution used _____ mL

31-2-2 Ascorbic acid determination

First titration Vitamin C solution _____ mL; Iodine solution used _____ mL.

Second titration Vitamin C solution _____ mL; Iodine solution used _____ mL.

Third titration Vitamin C solution _____ mL; Iodine solution used _____ mL.

Questions

31-1 Assume ascorbic acid is a single protic acid, use the data from acid-base titration to calculate the amount of ascorbic acid in the whole vitamin C tablet.

31-2 The reaction of I₂ with Na₂S₂O₃ is as shown:

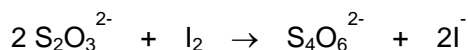

Calculate the concentration of the iodine solution.

31-3 The reaction of ascorbic acid with I₂ is

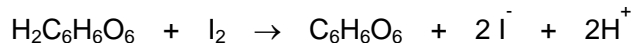

Calculate the amount of ascorbic acid in the whole vitamin C tablet.

31-4 Compare the advantage and disadvantage of the two titration methods.

Problem 32: Determination of an Equilibrium Constant

Equilibrium constant is an important property of a chemical reaction. It indicates the direction of a reaction. The concentration of each reaction species can be calculated from the equilibrium constant. For a reaction of the type $aA + bB \leftrightarrow cC + dD$, the equilibrium constant, K_{eq} , is given by $([\text{C}]_{\text{eq}}^c [\text{D}]_{\text{eq}}^d) / ([\text{A}]_{\text{eq}}^a [\text{B}]_{\text{eq}}^b)$. From the equation, K_{eq} can be easily computed if the concentrations of all species at equilibrium are known. Once the K_{eq} is determined, concentrations at equilibrium can be calculated from any given starting condition.

The aim of this experiment is to deduce the K_{eq} for the reaction of Fe(NO₃)₃ with KSCN. You are provided with 20 mL of a 0.1 M starter of each of the reactant: Fe(NO₃)₃ and KSCN. Three test

tubes containing the product from the reaction are also provided. Each of these contains a known concentration of the product: 3.214×10^{-3} , 1.360×10^{-3} , 1.375×10^{-4} M for tubes 1, 2, and 3; respectively. These standard solutions are used to be as colorimetric reference.

You have to design an experiment to determine the K_{eq} for the reaction of $Fe(NO_3)_3$ with KSCN using the given reagents. Your data should be listed in a table as shown below:

Starting conc. for reactant		Equilibrium conc. for reactant		Product conc.	Reaction equilibrium constant
$Fe(NO_3)_3$	KSCN	$Fe(NO_3)_3$	KSCN	?	K_{eq}
?	?	?	?	From colorimetric measurement	?

Carefully design your experiment before you start. More reagents can be obtained from the TAs upon request. However, 5 points will be deducted for each additional reagent. Marks for this experiment will be primarily awarded on the basis of the accuracy of the result.

Besides the reactants, the following equipment has also been provided on your bench:

1. Paper 3 sheets
2. Kimwipe 1 box
3. Labels
4. Test tubes (20 pieces) and a test tube rack
5. Safety bulb x 1
6. Rubber bulbs x 4
7. Pipette x 4
8. Glass rods x 2
9. Test tube brushes (thin and thick, one each)
10. Wash bottle x 1
11. Ruler (15 cm) x 1
12. Beaker 100 mL x 2
 250 mL x 2
 500 mL x 2

13. Graduated cylinder 10 mL x 1
 25 mL x 1
14. Volumetric 25 mL x 2
15. Erlenmeyer 100 mL x 4
16. Buret 5 mL x 2
 1 mL x 2

Data Sheet 32

Starting conc. for reactant		Equilibrium conc. for reactant		Product conc.	Reaction equilibrium constant
Fe(NO ₃) ₃	KSCN	Fe(NO ₃) ₃	KSCN		K _{eq}
				From colorimetric measurement	

Questions

32-1 Write a balanced equation for the reaction.

32-2 What is the expression for the equilibrium constant of this reaction?

K_{eq} =

32-3 What is the calculated value of K_{eq} from your data sheet?

Problem 33: Preparation of Acetylsalicylic Acid (Aspirin)

Acetylation of compounds containing the amino or hydroxyl group is usually accomplished by

means of acetyl chloride or acetic anhydride. The reaction is catalyzed by a catalyst such as pyridine or sulfuric acid.

Aspirin may be prepared from salicylic acid and acetic anhydride. Sulfuric acid is frequently used as a catalyst in this reaction.

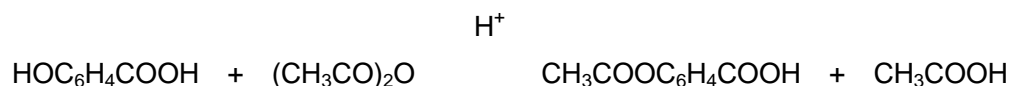

Procedure:

In a 125 mL Erlenmeyer flask place 3.5 g of salicylic acid, 3.5 mL of acetic anhydride (density: 1.08 g/mL), and 5 drops of concentrated sulfuric acid (some heat may be generated). Heat the flask in a hot water bath and stir for 5 minutes. During this time, the solid dissolve completely.

Remove the flask from the bath and add 15 mL of ice water to it. Cool the flask to crystallize the products. Collect the crystals by suction filtration.

Transfer the crystals to a 125 mL Erlenmeyer flask, add 8 mL of ethanol. Heat the flask in a water bath until the solid has dissolved. Add 20 mL of hot water to the flask and heat it until the solution clears. Remove the flask from the bath, cover it, and allow it to cool at room temperature. Collect the needle-like crystals by suction filtration. Wash the crystals with cold water and allow it to dry thoroughly.

Weight the crystals obtained and calculate the percentage yield of this experiment. Determine the melting points of the products.

Questions

33-1 What is the purpose of adding ice water?

33-2 Why the crystals was needed to wash with water?

33-3 Calculate the percentage yield of this reaction.

33-4 What is the melting point of aspirin you obtained?

Problem 34: Analysis of Aspirin Tablets

For many reasons, materials packaged for domestic use are often “diluted” by inert substances, often referred to as fillers. In the case of drugs, one reason for this procedure is to provide the correct dosage in a tablet of acceptable size. For example, aspirin, acetylsalicylic acid, is often mixed with a filler in commercial preparations. The aim of this experiment is to determine the percentage of aspirin in a readily available tablet.

Aspirin or acetylsalicylic acid can be considered to be the product of reaction of acetic acid (CH_3COOH) and salicylic acid ($\text{HOC}_6\text{H}_4\text{COOH}$). When treated with a solution of sodium hydroxide, aspirin is hydrolyzed and the two acids are simultaneously neutralized.

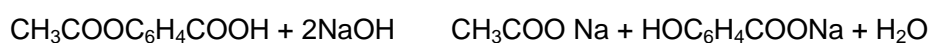

If an excess of NaOH solution is used in this reaction, the amount of excess can be determined by a back titration with H_2SO_4 . It is essential, however, that the H_2SO_4 used in this titration does not also react with sodium acetate and sodium salicylate, both of which contain basic anions. This can be avoided by the selection of either phenol red (pH range 6.8–8.4) or phenolphthalein (pH range 8.3–10.0) as the indicator.

Procedure:

Accurately weigh out sufficient aspirin tablets to give a mass of about 1.5 g. Record the number of tablets and the mass.

Transfer the tablets to a 150 mL conical flask. Add a 25 mL aliquot of a carefully prepared NaOH solution together with a similar volume of water. Heat gently for about 10 minutes to hydrolyze the acetylsalicylic acid, according to the equation above. Cool the reaction mixture by holding the flask under running water and carefully transfer the contents, without loss, to a 250 mL volumetric flask. Rinse the reaction vessel several times with water, adding the washings to the volumetric flask. Dilute the solution to the calibration mark and mix well by shaking.

Take a 25 mL aliquot of the diluted reaction mixture and transfer it to a clean conical flask.

Titrate the aliquot with 0.05 M H_2SO_4 solution using phenol red (or phenolphthalein) as the indicator. Record the actual molarity of the acid and the titre obtained. Repeat the determination until consistent titres are determined. Calculate the average titre.

Using a pipette and a volumetric flask, dilute a sample of the 1 M NaOH solution to 0.1 M.

Titrate 25 mL aliquots of the dilute solution with 0.05 M H₂SO₄ using the same indicator as before.

Questions

- 34-1 Why was it essential to cool the reaction mixture ?
- 34-2 Why was it essential to mix thoroughly?
- 34-3 With what should the pipette first be rinsed ?
- 34-4 With what should the flask have been rinsed ?
- 34-5 Why was it necessary to dilute the NaOH solution ?
- 34-6 Record the titres of acid and determine the molarity of the original NaOH solution, showing all steps in your calculation.
- 34-7 Determine the number of moles of NaOH originally added to the aspirin sample and the number of moles of NaOH used in the hydrolysis step.
- 34-8 Calculate the number of moles of acetylsalicylic acid present in the titre sample.
- 34-9 Calculate the mass of acetylsalicylic acid in each tablet and compare this with the specification shown on the package.
- 34-10 Analyze your own technique and assumptions in the experiment. List, in estimated order of importance, various sources of error which could arise in this analysis.

Problem 35: Resolution of (±) - α - Methylbenzylamine and Determination of the Optical Purity

The traditional method for resolving a racemic mixture into its enantiomers is to use an enantiomerically pure natural product that bonds with the compound to be resolved. The enantiomers in the racemic mixture bond with the optically pure resolving agent to form two diastereomers. The diastereomers are separated, and then the resolving agent is cleaved from the separated enantiomers. The optical purity of a compound is defined as the ratio of its optical

rotation to the rotation of a pure enantiomer.

A racemic mixture of α -methylbenzylamine is readily resolved by (*R,R*)-(+)-tartaric acid. The resulting (*S*)-(-)- α -methylbenzylaminium (*R,R*)-(+)-tartrate salt, *SRR*-salt, has a lower solubility than its diastereomeric counter part, (*R*)-(+)- α -methylbenzylaminium (*R,R*)-(+)-tartrate salt, *RRR*-salt. The *SRR* salt is induced to crystallize, whereas the *RRR* salt stays in solution. The crystals are removed by filtration and purified, and (*S*)-(-)- α -methylbenzylamine is regenerated by treatment with a base.

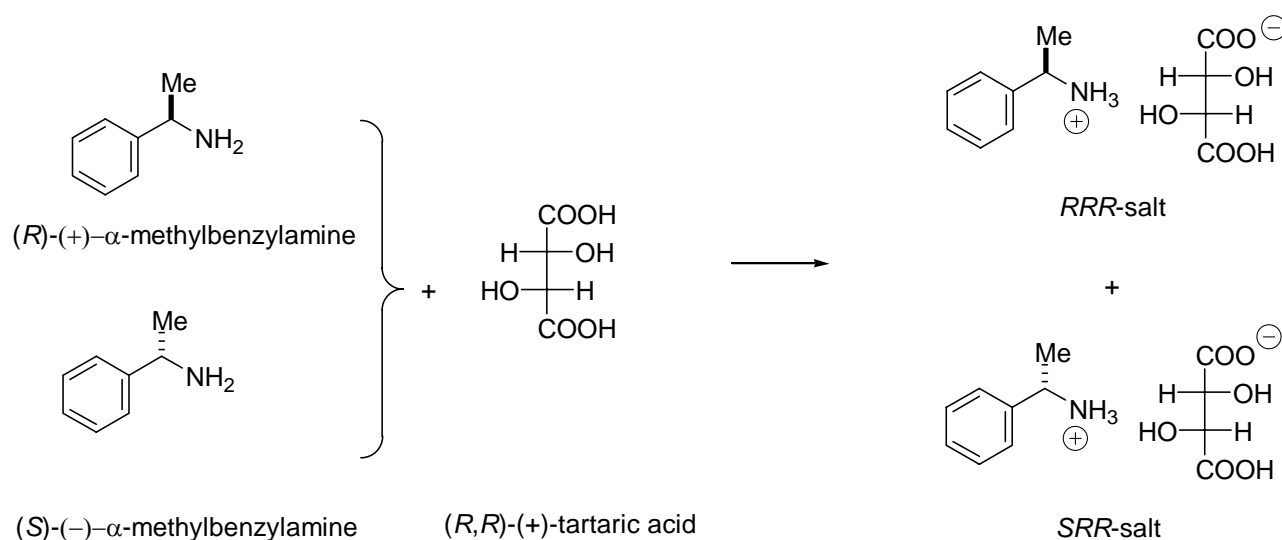

Procedure and Questions:

In an Erlenmeyer flask (250 mL) are placed (*R,R*)-(+)-tartaric acid (7.8 g, 52.0 mmol) and methanol (125 mL). The mixture is heated on a hot plate until the solution is nearly boiling. A racemic mixture of α -methylbenzylamine (6.25 g, 51.6 mmol) is added slowly over a period of 5 minutes to the solution. (*Caution: at this step, the mixture is very likely to froth and boil over*) Stopper the flask and let it stand overnight (18 hours). Formation of prismatic crystals indicates a complete resolution of enantiomers, whereas impure isomers will appear in needles. Needles should be dissolved by careful heating, and crystallized again on cooling slowly. A seed of prismatic crystal can be added to induce the recrystallization.

The crystals are filtered through a Büchner funnel, and rinsed with a few portions of cold methanol. The crystals are transferred to a preweighed Erlenmeyer flask (50 mL), and purged with a stream of nitrogen. The dry crystals are weighed, and the yield is calculated. The crystals in the flask are treated with water (25 mL), and 50% aqueous sodium hydroxide solution (4 mL) is added slowly. The mixture is extracted with 10 mL of methylene chloride for three times using a separatory funnel. The organic layers from each extraction are combined in a

stoppered flask, and dried over anhydrous sodium sulfate (1.0 g) for about 10 minutes. The dried solution is decanted into a round-bottom flask (50 mL), and methylene chloride is removed by rotary evaporation. The residual α -methylbenzylamine is weighed, and the yield is calculated. Every effort should be taken to avoid prolonged exposure of the amine to air. Transfer the α -methylbenzylamine into a polarimeter tube cell, and measure its optical rotation. The reported specific rotation of (S)-(-)- α -methylbenzylamine is $[\alpha]_D^{23} = -40.3^\circ$ (neat). Calculate the percentage for each of the enantiomers in the resolved sample.