

**USABO SEMIFINAL EXAMINATION**  
**March 9-18 2009**

***Part A***

- 1. If evolution has occurred:**
  - A. one species has split into two species.
  - B. the mean value for a trait has increased or decreased.
  - C. the allele frequencies in a population have changed.
  - D. the individuals in a population have had differential reproductive success.
  - E. the population is small.
  
- 2. Isotonic solutions are used as saline wash for wounds because:**
  - A. they kill contaminating bacteria.
  - B. they have lower salt concentration than the human body and would help healing.
  - C. they have the same salt concentration as the human body and will not irritate the wound.
  - D. they have higher salt concentration than the human body and would help healing.
  - E. they are bacteriostatic.
  
- 3. One reason phospholipids are well suited to be the main structural component of membranes is:**
  - A. they are completely insoluble in water.
  - B. they provide energy for transport through the membrane.
  - C. they form a structure in which the hydrophobic portion faces outward.
  - D. they form a single sheet in water.
  - E. they form a selectively permeable structure.
  
- 4. Natural selection is effective in the evolutionary processes because it:**
  - A. causes evolution.
  - B. changes allele frequencies.
  - C. changes genotype frequencies.
  - D. leads to fixation or loss of particular alleles.
  - E. increases the mean fitness of a population.
  
- 5. When cladists organize species into groups, these groups depict:**
  - A. physical similarities.
  - B. ecological niches.
  - C. chronological orders.
  - D. evolutionary relationships.
  - E. physiological similarities.
  
- 6. The main structure connecting the right and left hemispheres of the brain is the:**
  - A. thalamus.
  - B. cingulate gyrus.
  - C. corpus callosum.
  - D. interior commissure.
  - E. superior colliculus.

- 7. Inbreeding and genetic drift share all of the following EXCEPT that they:**
- A. lead to changes in genotype frequencies.
  - B. lead to a decrease in heterozygosity.
  - C. lead to an increase in homozygosity.
  - D. lead to changes in allele frequencies.
  - E. are more common in small populations.
- 8. A radially symmetrical animal that has two embryonic germ layers belongs to which phylum:**
- A. Aschelminthes
  - B. Cnidaria
  - C. Echinodermata
  - D. Platyhelminthes
  - E. Porifera
- 9. All of the following cells are alive in their functional state EXCEPT:**
- A. guard cells
  - B. mesophyll cells
  - C. pollen cells
  - D. tracheids
  - E. vascular cambium cells
- 10. The compensation depth of a lake is the depth where:**
- A. algal photosynthesis is no longer possible.
  - B. the rate of photosynthesis is equal to the rate of respiration.
  - C. oxygen production drops to zero.
  - D. the temperature no longer changes with increasing depth.
  - E. the depth of the photic zone equals the depth of the non-photoc zone.
- 11. A cloned gene relates to a vector as a:**
- A. passenger to a car.
  - B. driver to a car.
  - C. car mechanic to a car.
  - D. car mechanic to an environmental testing station.
  - E. passenger to a car mechanic.
- 12. Efferent arteriolar obstruction will result in an increase in:**
- A. plasma creatinine concentration.
  - B. renal blood flow.
  - C. heart rate.
  - D. calcium deposition on long bones.
  - E. filtration fraction.
- 13. Elevated levels of cortisol may result in which of the following?**
- A. Decreased gluconeogenesis
  - B. Increased facial hair in a woman
  - C. An increase in the ratio of epinephrine to norepinephrine released by the adrenal medulla
  - D. Enhanced immune function
  - E. Increased muscle mass

14. A child is born with erythroblastosis fetalis. Which of the following is acceptable?
- A. The child must be the first conceptus of the mother.
  - B. The mother was treated with the carcinogen *Rhogam* during pregnancy.
  - C. Anti-D antibodies were introduced into the mother by a previous pregnancy.
  - D. The father must be Rh-negative.
  - E. Erythroblastosis fetalis leads to decreased red blood cell synthesis.
15. Which of the following statements is NOT true regarding B cells?
- A. They are formed in the bone marrow.
  - B. They develop into plasma cells and memory cells.
  - C. They recognize peptide antigens by the major histocompatibility complex molecules.
  - D. They are the source of antibodies.
  - E. They are lymphocytes.
16. Cancer is a collective disease associated with uncontrollable cell growth. Mutation in which of the following types of genes is LEAST likely to result in higher chances of developing cancer.
- A. Tumor necrosis factor gene
  - B. Tumor suppressor gene
  - C. Oncogene
  - D. Proto-oncogene
  - E. Anti-oncogene
17. Substances that excite  $\beta_2$  adrenergic receptors ( $\beta$ -agonists) are used to treat asthma and COPD (Chronic Obstructive Pulmonary Disease). These drugs can have significant side effects including:
- A. decreased sensitivity to inflammation, inhibition of uterine contraction, hypotension.
  - B. hypotension, increased blood pressure, decreased plasma potassium.
  - C. hypertension, dizziness, vasoconstriction.
  - D. bronchial-dilation, increased uterine contraction, increased serum angiotensin.
  - E. dizziness, bronchial-constriction, decreased sensitivity to inflammation.
18. An individual with rampant untreated type I diabetes is brought to the emergency room. Following an emergency injection of insulin all of the following would occur EXCEPT a decrease in:
- A. the renal clearance of glucose.
  - B. plasma  $K^+$ .
  - C. blood pH.
  - D. rate of lipolysis.
  - E. respiratory rate.
19. \_\_\_\_\_ are to termites as \_\_\_\_\_ are to plants.
- A. Cellulose molecules, water molecules
  - B. Gut microbes, mycorrhizal fungi
  - C. Predators, prey
  - D. Gut microbes, water molecules
  - E. Hours of darkness, hours of light
20. The 4 layers of the digestive tract from the inside out are:
- A. serosa, muscular layer, mucosa, submucosa.
  - B. serosa, muscular layer, submucosa, mucosa.
  - C. mucosa, submucosa, muscular layer, serosa.
  - D. submucosa, mucosa, serosa, muscular layer.
  - E. muscular layer, serosa, mucosa, submucosa.

- 21. A beaver gnawed completely around a tree trunk but did not proceed further. The leaves on the tree remained green for a long period of time, but eventually the tree died. It is probable that the tissue left intact by the gnawing of the beaver was the:**
- cork cambium.
  - cortex.
  - hypodermis.
  - phloem.
  - xylem.
- 22. The first (S1) and second (S2) heart sounds are due to which of the following, respectively?**
- The closing of the AV valve and opening of bicuspid valve.
  - The closing of the bicuspid valve and the opening of the mitral valve.
  - The closing of the semilunar valve and the closing of the tricuspid valve.
  - The closing of the AV valve and the closing of the semilunar valves.
  - The closing of the tricuspid valve and the closing of the mitral valve.
- 23. Trace the flow of filtrate through the nephron as it enters the kidney through the renal artery.**
- proximal convoluted tubule
  - collecting duct
  - descending limb of loop of henle
  - bowman's capsule
  - distal convoluted tube
  - ascending limb of loop of henle
- 4,5,6,3,1,
  - 4,1,6,3,5,
  - 4,5,3,6,1,2
  - 4,1,3,6,5,2
  - 4,6,3,1,5,2
- 24. If you wanted to genetically engineer a plant to be more resistant to drought, increasing the amount of internal production of which of the following hormones might be a good first attempt?**
- Abscisic acid
  - Auxin
  - Brassinosteroids
  - Cytokinins
  - Gibberellins
- 25. The Casparian strip in a plant root blocks transport of water and minerals traveling in the:**
- apoplast.
  - cytoplasm.
  - plasmodesmata.
  - symplast.
  - xylem.
- 26. What is the relationship between pollination and fertilization in flowering plants?**
- If fertilization occurs, pollination is unnecessary.
  - Fertilization precedes pollination.
  - Pollination easily occurs between plants of different species.
  - Pollen is formed within megasporangia, which means that male and female gametes are near each other.
  - Pollination brings gametophytes together so that fertilization can occur.

27. Which of the following populations is most likely to be close to Hardy-Weinberg equilibrium?
- The human population of Toronto, Canada.
  - A population of 100 fruit flies living in a habitat with little environmental fluctuation that has no other populations of fruit flies nearby.
  - A population of 1 million fruit flies living in a habitat with little environmental fluctuation that has many other populations of fruit flies nearby.
  - A population of 100 fruit flies living in a habitat with little environmental fluctuation that has many other populations of fruit flies nearby.
  - A population of 1 million fruit flies living in a habitat with little environmental fluctuation that has no other populations of fruit flies nearby.
28. “Year after year, men cruising timber or hunting deer in the Blue Mountains of eastern Oregon had come back with the same story. Near the little hamlet of Kamela they had heard a faraway tinkling, a ghostly bell ringing. No one was able to track down the strange sound. It would fade away in the sighs of the wind through the big pines. Skeptics accused the men of hearing things. Last week, while slashing a right-of-way for a power line from *Bonneville Dam*, lumberjacks brought down a ponderosa pine. Tied by a shriveled leather thong, high in the tree top, was the answer to the mystery of Kamela; a bronze cattle bell inscribed with the date 1878. The people of Kamela guessed that a pioneer had tied it to a sapling that had grown to a towering pine.” (*Time Magazine*, 1937) Which of the following is the best appraisal of the concluding sentence of the above report?
- Logical because this tree could have attained great height since 1878.
  - Logical because a tree trunk elongates from the base up.
  - Illogical because no one knows with certainty when the bell was tied to the sapling.
  - Illogical because elongation of a tree trunk occurs from the apical meristem up.
  - There is no basis for appraising the concluding sentence of the report.
29. Spores:
- are typically produced by sporophytes via mitosis.
  - arise from pollination.
  - give rise to gametophytes.
  - give rise to sporophytes.
  - were worn by John Wayne in many of his movies.
30. Identify the family that includes (mostly) terrestrial perennials with broad leaves and unusual columnar inflorescences (spadix) that are often subtended by a single bract (spathe).
- Araceae
  - Cactaceae
  - Lamiaceae
  - Liliaceae
  - Orchidaceae
31. Arrange the following five events in an order that explains the bulk flow of substances in the phloem.
- sugar moves down the stem
  - leaf cells produce sugar by photosynthesis
  - sugar is transported from cell to cell via the apoplast and/or symplast
  - solutes are actively transported into sieve elements
  - water diffuses into the sieve tube elements
- 2,1,4,3,4
  - 1,2,3,4,5
  - 2,4,3,1,5
  - 4,2,1,3,5
  - 2,4,1,3,5

- 32. A population of fish has remained virtually unchanged in size, shape, and habitat preference during a period of 50 million years. Which is likely to have occurred in this population?**
- A. No mutation and no natural selection have occurred.
  - B. Mutation has occurred, but disruptive selection has worked against the mutation rate to keep the population unchanged.
  - C. Mutation has occurred, but stabilizing selection has worked to keep the population unchanged.
  - D. Mutation has occurred, but directional selection has worked to push the population in the direction of its current form.
  - E. This population is inherently resistant to genetic change.
- 33. Which of the following conditions is required for phototropism?**
- A. Active metabolic transport system
  - B. Energy supplied by photosynthesis
  - C. Gravity
  - D. Melanin
  - E. Photoreceptor
- 34. SNPs can be characterized by all of the following EXCEPT for:**
- A. always causing diseases.
  - B. being common in a population.
  - C. acting as a point mutation.
  - D. acting as a transition mutation.
  - E. being useful in genotyping.
- 35. In a paper by Endler, female guppies tend to choose more brightly colored males for mates. The bright colors are an indicator of male health and potential as a mate. However, they also make the males more conspicuous to predators. Which of the following outcomes is most likely?**
- A. All populations will become more colorful over time.
  - B. All populations will become less colorful over time.
  - C. Populations exposed to intense predator pressure will tend to remain less colorful than those not exposed to such pressure.
  - D. Populations exposed to intense predator pressure will tend to become more colorful than those not exposed to such pressure.
  - E. Guppies could become extinct due to conflicts between natural selection and sexual selection.
- 36. A female lizard washes ashore on an island after riding a floating log for hundreds of miles across the sea. She is the only member of her species to have ever made it to the island. After arriving, she lays 20 fertile eggs that hatch and form the basis of a lizard population on the island. Which of the following is NOT a likely result?**
- A. The new island population will have less genetic diversity than the ancestral population.
  - B. Mutation will add new alleles to the new population and thus increase its genetic diversity over time.
  - C. There will be little or no gene exchange between the new population and the ancestral population.
  - D. The new island population will have greater genetic diversity than the ancestral population.
  - E. Directional selection may push the population to be different from the ancestral population.
- 37. Loss of heterozygosity can be caused by all of the following EXCEPT:**
- A. genetic drift.
  - B. positive frequency-dependent selection.
  - C. heterozygote advantage.
  - D. inbreeding.
  - E. heterozygote disadvantage.

- 38. The amino acid sequences encoded by the red and green visual pigment genes in humans are 96% identical. These two loci are found close together on the X chromosome. What mechanism most likely led to the evolution of these two genes?**
- A. Horizontal gene transfer followed by sequence divergence
  - B. Gene duplication followed by sequence divergence
  - C. Inversion of the human X chromosome
  - D. Polyploidization
  - E. Translocation of a piece of chromosome 7 to the X chromosome
- 39. Black color in horses is governed primarily by a recessive allele at the A locus. AA and Aa horses are nonblack colors such as a Bay or a Dunn. The A and a alleles are in Hardy-Weinberg equilibrium. Which of the following statement(s) is/are ACCEPTABLE?**
- A. Nonblack horses should become more common because A is dominant.
  - B. Black horses should become more rare because a is recessive.
  - C. A and B
  - D. Horses probably choose their mate based on color.
  - E. The frequencies of the A and a alleles do not change.
- 40. Genetic drift is best described as:**
- A. evolutionary change due to natural selection.
  - B. changes in the proportion of homozygous recessive individuals due to random mating.
  - C. a random change in allele frequencies that benefits the population.
  - D. evolutionary change due to random events.
  - E. evolutionary change due to non-random mating.
- 41. Which of the following maintains genetic variation?**
- A. Homozygote advantage
  - B. Heterozygote disadvantage
  - C. Positive frequency-dependent selection
  - D. Negative frequency-dependent selection
  - E. None of the above
- 42. If a gene is fixed in a population:**
- A. the gene cannot undergo mutation.
  - B. one allele exhibits complete dominance over the other allele of that gene.
  - C. only one allele appears for that gene in the population.
  - D. the gene causes the organism to be infertile.
  - E. the gene is located near the centromere on the chromosome, reducing its ability to recombine.
- 43. The central proposition of the neutral theory is that:**
- A. most genotypic variation that we see has no selection acting on it.
  - B. most phenotypic variation that we see has no selection acting on it.
  - C. we can infer from the genetic code that most mutations are non-synonymous.
  - D. the molecular clock is flawed, because substitution rates depend on the population size.
  - E. selection acts upon the most fit phenotype thus affecting the genotype.
- 44. If an amoeba had more DNA than a human the most likely explanation is:**
- A. amoebas are more complex than humans.
  - B. amoebas have more genes than humans.
  - C. amoebas have a larger transcriptome (all the messenger RNA) than humans.
  - D. amoebas have a larger proteome (all the proteins) than humans.
  - E. amoebas have more junk DNA than humans.

- 45. Which of the following statements about allopatric speciation is UNACCEPTABLE?**
- A. Allopatric speciation is also called geographic speciation.
  - B. Allopatric speciation requires that daughter populations be fairly small when first separated.
  - C. Continental drift resulted in allopatric speciation.
  - D. The founder effect may result in daughter populations having a more limited set of alleles than the parent population.
  - E. Allopatric speciation is the most common form of speciation.
- 46. The Species-Area Relationship suggests that 10% of a given area supports:**
- A. 90% of species.
  - B. 70% of species.
  - C. 50% of species.
  - D. 30% of species.
  - E. 10% of species.
- 47. As blood passes through a capillary bed, which of the following occurs?**
- A. Osmotic pressure decreases and net pressure is constant
  - B. Osmotic pressure increases and net pressure is constant
  - C. Osmotic pressure is constant and net pressure decreases
  - D. Osmotic pressure is constant and net pressure increases
  - E. Both osmotic and net pressure are constant
- 48. A declining population of an endangered species is determined to have an exponential rate of decrease of  $r = -0.02$ . What is the corresponding value of  $\lambda$  for this population?**
- A. exactly 1
  - B. greater than 1
  - C. greater than 0 and less than 1
  - D. 0
  - E. less than 0
- 49. There are two alleles of a gene, A and a, at frequencies 0.7 and 0.3, respectively, in a population. By chance, the frequency of A is 0.71 and the frequency for a is 0.29 in the next generation. This change in allele frequency is:**
- A. the result of random mating.
  - B. evolution.
  - C. the result of natural selection.
  - D. impossible in a small population.
  - E. too small to have any effect over long periods of time.
- 50. Twenty-five randomly collected members of a white-footed mouse population were marked and released on Day 0. Ten mice from the white-footed mouse population were recaptured a week later and 1 was marked. How large was the mouse population on Day 0 (assuming no mortality between Day 0 and recapture)?**
- A. 2500
  - B. 250
  - C. 10
  - D. 25
  - E. 5



- 51. Which description best describes what would happen to the carbon cycle if all detritivores suddenly went on “strike” and stopped working?**
- A. Carbon would increase in inorganic mass, while the atmospheric reservoir of carbon would continue to increase and plants would not be jeopardized.
  - B. Carbon would increase in organic mass, while the atmospheric reservoir of carbon would increase and plant-life would be starved for CO<sub>2</sub>.
  - C. Carbon would decrease in organic mass, while the atmospheric reservoir of carbon would increase with the result that plant-life would be starved for CO<sub>2</sub>.
  - D. Carbon would decrease in organic mass, the atmospheric reservoir of carbon would increase, and plants would maintain an even balance of CO<sub>2</sub>.
  - E. Carbon would accumulate in organic mass, the atmospheric reservoir of carbon would decline, and plants would eventually be starved for CO<sub>2</sub>.
- 52. For the phosphorus cycle, why (in the short term) does phosphorus cycling tend to be more localized than either carbon or nitrogen cycling?**
- A. Because phosphorus is ultimately transferred almost entirely via the atmosphere rather than almost entirely via the soil (locally).
  - B. Because phosphorus is both transferred locally in the atmosphere, as well as in the soil (in the short term).
  - C. Because carbon as well as phosphorus cycle in the soil (locally), while only nitrogen is transferred atmospherically.
  - D. Because phosphorus is cycled almost entirely within the soil rather than transferred over long distances via the atmosphere.
  - E. Because short term phosphorous cycling is not localized more in either carbon or nitrogen cycling.
- 53. A new species of a terrestrial animal is discovered with the following characteristics: exoskeleton; tracheal system for gas exchange; and modified segmentation. A knowledgeable zoologist would predict that the terrestrial animal’s parents would also most likely have:**
- A. eight legs.
  - B. four legs.
  - C. parapodia.
  - D. sessile lifestyle.
  - E. wings.
- 54. CO<sub>2</sub> emissions from the Northern Hemisphere are 6.1 Pg C/yr, and 0.8 Pg C/yr from the Southern Hemisphere. However, the total amount of CO<sub>2</sub> in the atmosphere over the Northern Hemisphere is not much greater than the amount in the atmosphere over the Southern Hemisphere (376 versus 374 Pg C).**

**Why is there such a big difference in emissions between the two hemispheres?**

- A. The presence of the tropical rainforests in the Southern Hemisphere results in a greater uptake of carbon dioxide.
- B. The presence of higher population number of photosynthetic bacteria the Southern Hemisphere results in a greater uptake of carbon dioxide.
- C. The destruction of tropical rain forests through slash and burn agriculture increases the emission of carbon dioxide.
- D. Carbon credits are being distributed solely to industries in the Northern Hemisphere.
- E. There is a greater land mass in the Northern Hemisphere, which supports more people and thus more burning of fossil fuels.

- 55. You are interested in studying water absorption and feces production in the large intestine. You create a knockout mouse strain unable to make aquaporins in the large intestine. The mice still produce feces, but they are wetter than normal. These results suggest:**
- A. active water transport is essential for water absorption in the large intestine.
  - B. active water transport is not involved in water absorption in the large intestine.
  - C. active water transport is involved in but not essential for water absorption in the large intestine.
  - D. passive water transport is essential for water absorption in the large intestine.
  - E. passive water transport is involved in but not essential for water absorption in the large intestine.
- 56. Response to sign stimuli or releasers is generally based upon:**
- A. how realistic they are.
  - B. how colorful they are.
  - C. a few isolated features of the stimulus.
  - D. whether all members of the species have them.
  - E. whether the stimulus is adaptive.
- 57. Why would some fears be "built in"?**
- A. They involve stimuli which can have many different meanings.
  - B. They involve hallucinations which come from inside the animal.
  - C. They aided survival and reproduction of ancestor animals.
  - D. They are reinforced by early experience during the "imprinting" stage.
  - E. So that animals can "unlearn" them, according to Thorndike, if the environment is safe.
- 58. Which of the following statements are correct about diversity in ecological environments?**
- A. Ecological stress increases diversity.
  - B. Animals that share a common habitat are typically more closely related than animals in different environments.
  - C. Natural selection decreases diversity.
  - D. Diversity is most often seen in small populations.
  - E. Changes in diversity of host species have little effect on other species.

59. Lions are cooperative hunters, and the rate of food intake for an individual lion increases up to a point as hunting group size increases. Theoretically after more than three lions are in a group, the rate of food intake for an individual lion (often referred to as the per capita rate) begins to decrease. See the graph below. Actual observations indicate the average hunting group size in lions is four. Which of the following is a legitimate explanation for why lion group size may be higher than predicted by optimality models?

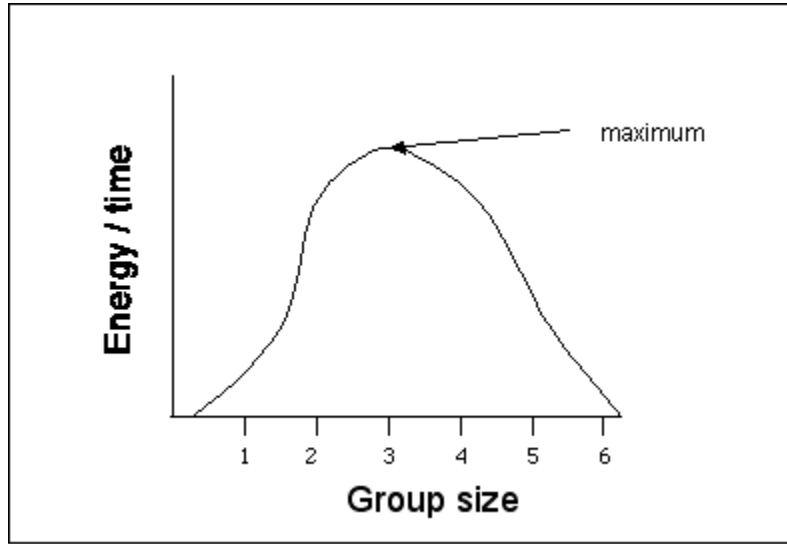

- A. Sub-adult males join the group.  
B. The knowledge about optimal group size is imperfect.  
C. The group is made of several young lions.  
D. Dominant male lions typical hunt with their females and they generally have more than two.  
E. Only three lions cannot take down large prey.
60. The red-faced twit forms winter flocks of two individuals. Individual twits can adopt one of two strategies: either watch for predators or not watch. If at least one of the pair watches, both members survive the winter. If a twit is a member of a flock in which neither watches, there is a 40 percent chance that it is killed. Non-watchers get more to eat, so if they do survive, they raise five offspring the following summer, whereas watchers raise only four offspring. Assume that  $p$  is the fraction of watchers in the population. At equilibrium, the proportion of Watchers in the population is:
- A.  $1/3$   
B.  $2/5$   
C.  $1/2$   
D.  $3/5$   
E.  $3/4$

## 2009 USABO Semi-Final Exam - Part B

Question 61 -91 have only a single correct answer and are valued at 1.5 points each. (46.5 points)

Questions 61-64. A new reproductive technique has been developed to treat women with a particular type of infertility. This type of infertility is caused by defects found in the cytoplasm of some egg cells. For this reason, the nucleus is removed from the egg of the infertile mother and placed into an enucleated donor egg from another individual.

Linda and Bob wish to have a child by this new assisted reproductive technique. Neither has a family history of genetic conditions. The proposed donor of the enucleated egg is an apparently healthy 23 year-old woman with the following family history. Affected individuals of degenerative-optomosis have rapid loss of vision due to optic nerve death beginning in the mid-twenties. The prevalence of this disease is 1 in every 10,000 individuals.

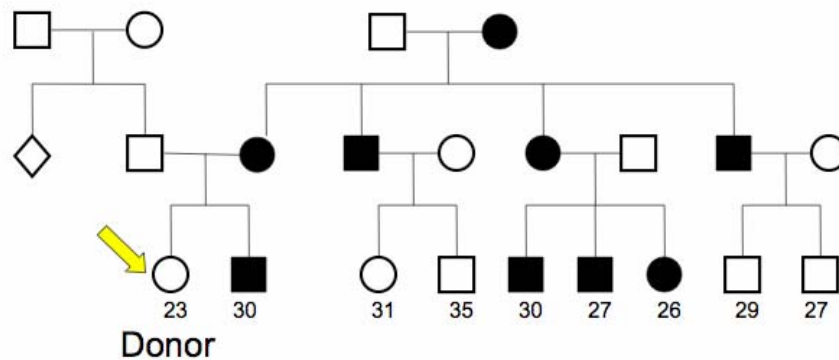

61. What is the most likely mode of inheritance pattern of degenerative-optomosis in the donor's family?
  - A. X-linked recessive
  - B. X-linked dominant
  - C. Mitochondrial
  - D. Genomic imprinting
  - E. Autosomal recessive
62. Acceptable/Unacceptable: The donor is at risk for vision loss by degenerative-optomosis.
  - A. Acceptable
  - B. Unacceptable
63. Acceptable/Unacceptable: Linda and Bob's child will not be at risk for vision loss by degenerative-optomosis.
  - A. Acceptable
  - B. Unacceptable
64. What is Linda's risk of the vision loss by degenerative-optomosis?
  - A. 1/1
  - B. 1/2
  - C. 1/4
  - D. 1/10,000
  - E. 1/20,00

Questions 65-69. Characterize the following selective events as one of the following choices. Indicate the letter of the appropriate selection on your answer sheet for each of the following examples.

- A. Directional
- B. Stabilizing
- C. Disruptive
- D. Positive Frequency-Dependent Selection
- E. Negative Frequency-Dependent Selection

65. Selection on the size of crabs results in differences in size between two populations. This is because smaller ones can eat small prey efficiently but cannot eat large prey, and the large ones can eat large prey, but don't bother with prey that is too small. Intermediate-sized crabs are not able to manipulate the smaller prey items, but they are excluded from the larger prey items by the larger crabs.

66. More intense red coloration in roses is favored by horticulturalists and the population of roses becomes redder in color.

67. Frogs call to attract mates. Most male frogs call in choruses at a specific time of night. Females are attracted to males that call at this time of night because they are preoccupied during earlier times, and they get sleepy at later times.

68. Two populations of a species of frog live around the Gulf of Mexico. One population has a brown back and lives on rocky islands with brown rocks and little vegetation. A second population lives on the mainland among the vegetation and has a back that is speckled with green and browns.

69. Birds seek larvae of a certain species of butterflies that vary in their feeding behavior. Some larvae feed on the under sides of leaves, some larvae feed beneath the bark, and some larvae feed while resting on stems. The birds learn where they are likely to find larvae and focus their feeding on places where they have been successful in finding larvae. What sort of selection is exerted on the butterfly larvae?

For questions 70-76, refer to the diagram below of two neurons and a glial cell.

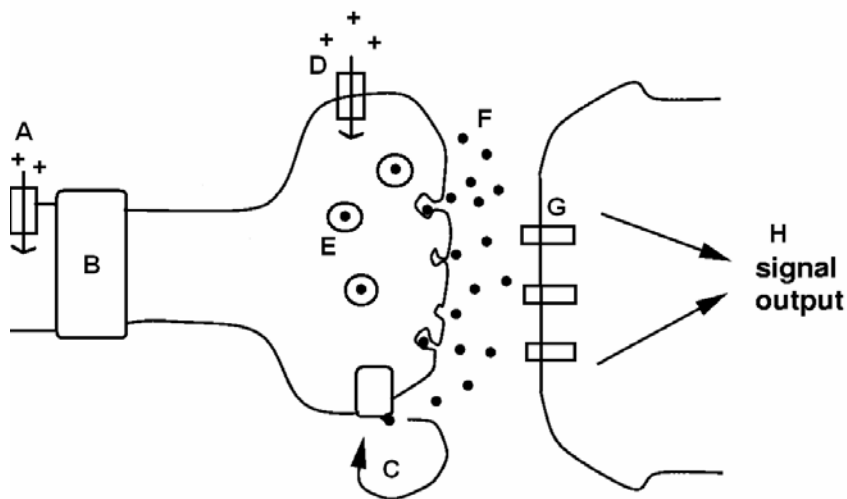

For each of the following drug molecules, determine which location it will effect on the diagram above and record the letter representing that location on your answer key. (Use the letters E, F, G and H only in question #76)

70. Selective serotonin reuptake inhibitor

71. Lorenzo's Oil (medicine used to rebuild degenerated myelin)

72. Botulinium Toxin (prevents action potential propagation)

73. Barbituate (antiepileptic that prevents voltage-gated Na<sup>+</sup> channels from functioning)

74. Ethosuximide (antiepileptic that prevents Ca<sup>2+</sup> initiated action)

75. A vesicle transport inhibitor

76. Acetylcholinesterase is an enzyme that breaks down Acetylcholine. This enzyme most likely functions at which location on the diagram?

- A. E
- B. F
- C. G
- D. H

For questions 77-91 refer to the following figure.

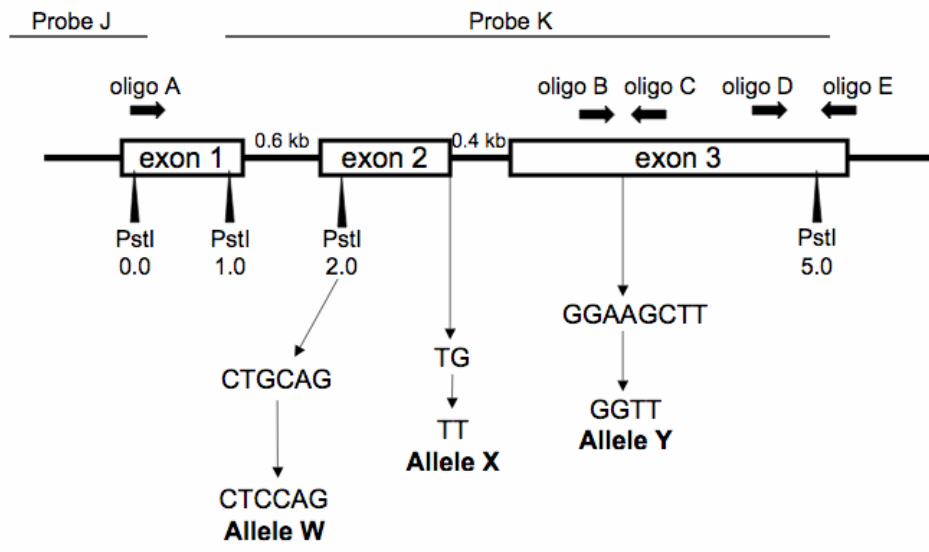

You have been hired as a consultant for a halitosis support group. Assume that stinky breath is an autosomal recessive disorder whose gene has been cloned and is expressed in the blood. You obtain blood samples from affected individuals and controls, and send them off to the lab for analysis. The results come back, with the diagnoses and raw data for each person but the autoradiographs have been mixed up. Many of your clients in the support group are scientists who want to see the raw data, so you have to figure out what goes with what. Assume that each halitosis patient is homozygous for one of four restriction endonucleases. The map shows the location of each mutation, how the normal sequence is altered, and diagnostic probes and oligos used.

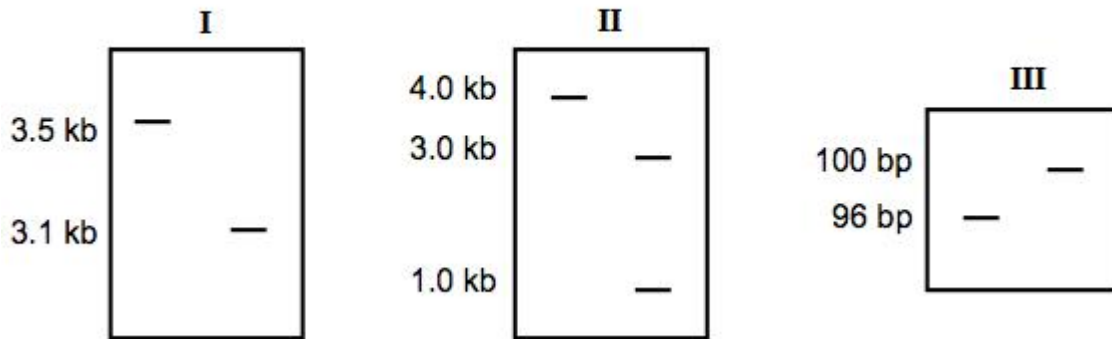

Of the three tests above, one represents a Southern blot, one a Northern blot, and one a gel of the PCR products of a PCR reaction. Each has two specimens, one from a patient and one of control.

77. What is the allele detected in test result I?

- A. W
- B. X
- C. Y

78. What lane represents the patient in test result I?

- A. Left
- B. Right

79. What material is being analyzed in test result I?

- A. DNA
- B. RNA
- C. DNA and RNA
- D. Protein

80. What type of analysis is represented in test I?

- A. Northern
- B. Southern
- C. PCR gel

81. What probe(s) or primer(s) could have been used for the analysis of test result I?

- A. Probe J
- B. Probe K
- C. Primers A and C
- D. Primers A and B
- E. Primers B and C

82. What is the allele detected in test result II?

- A. W
- B. X
- C. Y

83. What lane represents the patient in test result II?

- A. Left
- B. Right

- 84. What type of analysis is represented in test II?**  
A. Northern  
B. Southern  
C. PCR gel
- 85. What material is being analyzed in test result II?**  
A. DNA  
B. RNA  
C. DNA and RNA  
D. Protein
- 86. What probe(s) or primer(s) could have been used for the analysis of test result I?**  
A. Probe J  
B. Probe K  
C. Primers A and C  
D. Primers A and B  
E. Primers B and C
- 87. What is the allele detected in test result III?**  
A. W  
B. X  
C. Y
- 88. What lane represents the patient in test result III?**  
A. Left  
B. Right
- 89. What type of analysis is represented in test result III?**  
A. Northern  
B. Southern  
C. PCR gel
- 90. What material is being analyzed in test result III?**  
A. DNA  
B. RNA  
C. DNA and RNA  
D. Protein
- 91. What probe(s) or primer(s) could have been used for the analysis of test result III?**  
A. Probe J  
B. Probe K  
C. Primers A and C  
D. Primers A and B  
E. Primers B and C



For questions 92 – 132 determine whether the choices following each statement are acceptable (A) or unacceptable (B). Each is valued at 0.5 points. (20.5 points)

**Plants may cope with chronically nitrogen-poor soils by which of the following adaptations?**

92. By establishing symbiotic relationships with fungi
93. By growing slowly and retaining leaves for long periods
94. Increased root growth and root hair development
95. Enhanced expression of  $\text{NH}_4^+$  and  $\text{NO}_3^-$  transporters
96. Insectivory

**In a population model which of the following must be determined in order to derive  $r_d$ ?**

97. Survival rates (sx)
98. Expectations of life (ex)
99. Net reproductive rate ( $R_0$ )
100. Generation time (T)

**Compared to source populations, sink populations in source-sink models have:**

101. low growth rate.
102. high emigration rate.
103. high immigration rate.
104. low extinction coefficient.
105. high growth rate.

**In a population model which of the following must be determined in order to derive  $r_d$ ?**

106. Survival rates (sx)
107. Expectations of life (ex)
108. Net reproductive rate ( $R_0$ )
109. Generation time (T)

**Why isn't nuclear energy currently being considered as the best major, long-term energy resource?**

110. It has a high risk of environmental and human health damage.
111. It is not as cost-effective.
112. It can contribute to nuclear weapon development.
113. It does not provide as much energy as do other resources.
114. It presents problems of waste disposal.

**Deforestation contributes to:**

115. habitat fragmentation.
116. climate change.
117. soil degradation.
118. extinction.
119. an increase in species diversity.

**The foraging behavior in fruit fly larvae takes two forms. In one form larvae forage across longer paths, while in the second form the larvae forage over shorter distances. A gene called *rover* is present in flies exhibiting the first behavioral phenotype while absent in the second. Why would flies expressing *rover* have higher fitness when population density is high?**

120. As food supplies become limited, *rover* larvae will move to distant food sources.
121. As food supplies become limited, *rover* larvae will out-compete for available food.
122. As food supplies become limited, *rover* larvae can utilize alternate food types for nutrition.

**Which of the following cells are phagocytic?**

- 123. Megakerocyte
- 124. Dendritic cells
- 125. Natural killer cells
- 126. Neutrophils
- 127. Monocytes

**Celiac is an autoimmune disorder which causes destruction of the villa in the small intestines. A person with Celiac disease may present with which of the following?**

- 128. Failure to thrive
- 129. Jaundice
- 130. Steatorrhea
- 131. Anemia
- 132. Abdominal pain

*Name* \_\_\_\_\_  
*Student ID Number* \_\_\_\_\_  
*School* \_\_\_\_\_

## ***2009 USABO Semi-Final Exam - Part C***

**Questions 1-10 have a total value of 20 points.**

You decide to clone your favorite gene *Kull* into a plasmid with a selectable marker. You transform into XL10 Gold cells and then plate the cells onto selective media. You then put your plates in the 25° C incubator. The next day you look at your plates, and see that your colonies are much smaller than those of the other students.

1. In two sentences or less explain why this happened.
  
  
  
  
  
  
  
  
  
  
2. Should you repeat this transformation? Why or why not?

You perform another transformation, plating 50  $\mu$ L of the transformation mixture directly onto non-selective and selective plates. You observe several colonies on both. The non-selective plate contained 800 colonies, while the selective plate contained 50 colonies.

3. Calculate the transformation efficiency.
  
  
  
  
  
  
  
  
  
  
4. Provide a specific reason for why only 50 colonies grew on your selective plate while 800 grew on the non-selective plate.

*Name* \_\_\_\_\_  
*Student ID Number* \_\_\_\_\_  
*School* \_\_\_\_\_

5. You perform a new transformation and calculate a viable count of 5000 cells/mL of your transformed solution. If your transformation efficiency was 5%, how many colonies would you expect to see if you plate 100  $\mu$ L of cells onto selective media?

6. You decide to perform the same site-directed mutagenesis experiment you performed in class. You perform SDM PCR on a 3.6 kb plasmid containing *CRYGD*, DpnI digest the parental template, transform XL10 Gold cells and then plate on complete media containing ampicillin. Determine whether or not each of the following plasmids will be effective in your experiment. Explain why or why not.

Name \_\_\_\_\_  
Student ID Number \_\_\_\_\_  
School \_\_\_\_\_

Plasmid A:

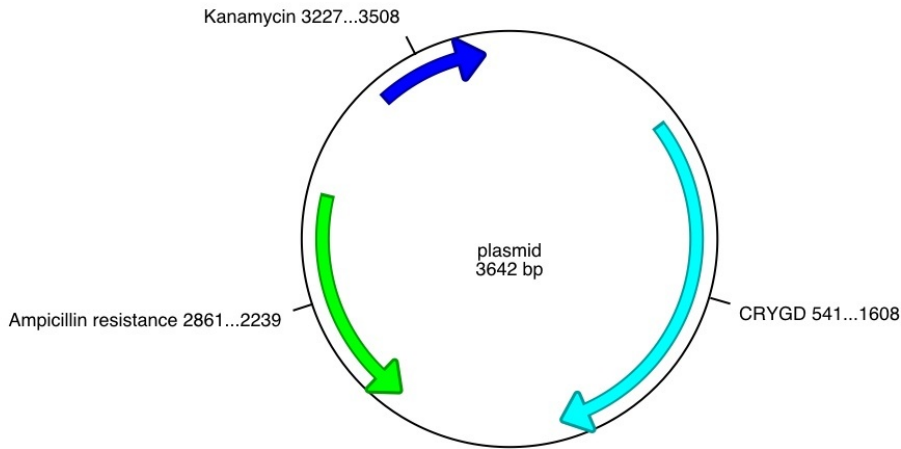

7. Will this plasmid work in your experiment? Yes No

8. Why or why not?

Plasmid B:

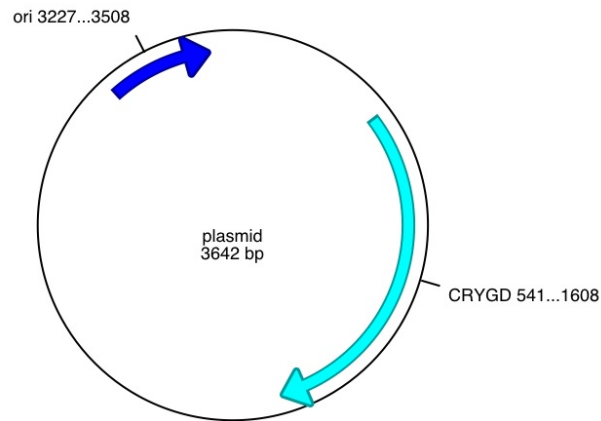

9. Will this plasmid work in your experiment? Yes No

10. Why or why not?

Name \_\_\_\_\_  
 Student ID Number \_\_\_\_\_  
 School \_\_\_\_\_

Question 11-30 have a total value of 20 points.

For each of the following characteristics, place an X in the box for each plant group in which the characteristic might be found.

NUMBER	CHARACTER	FERN	GYMNOSPERM	DICOT	MONOCOT
11	Seed				
12	F lower				
13	Fruit				
14	Endosperm				
15	1 Cotyledon				
16	2 Cotyledons				
17	Many Cotyledons				
18	Vascular Cambium				
19	Phellogen				
20	Wood				
21	Resin Ducts				
22	Xylem Vessels				
23	Xylem Tracheids				
24	Phloem Sieve Cells				
25	Phloem Sieve Tube Cells				
26	Pollination				
27	Archegonia				
28	Antheridia				
29	Sorus				
30	Strobili				