

**USABO Open Exam
February 4 to 14, 2014**

***Addendum:** Directions for all USABO Open Exam questions are included in the “Student Certification Form” with the exception of Questions 6, 14, 22, 27, 28, 32, 35, 39, 41, and 46. These questions use a different question format—Multiple True-False. Directions for answering each of these questions are included with each question.*

1. Why is myelin important in the nervous system?

- A. It allows signals to travel faster along axons because depolarization occurs only at myelinated locations.
- B. It allows signals to travel faster along axons because depolarization occurs only at non-myelinated locations.
- C. It bundles the dendrites of adjacent neurons together.
- D. It increases capacitance across the cell membrane, which helps electrical signals to leave the axons.
- E. It traps neurotransmitters, increasing their concentrations in the synaptic cleft.

2. Which type of cytoskeletal fiber is the primary building block of eukaryotic cilia and flagella?

- A. Actin microfilaments.
- B. Intermediate filaments.
- C. Keratin.
- D. Microtubules.
- E. RNA.

3. Which of the following human cell types contains the LEAST amount of RNA involved in splicing?

- A. Lymphocytes
- B. Lymphoblasts
- C. Erythrocytes
- D. Erythroblasts
- E. Hepatocytes

4. Antimicrobial drugs, also known as antibiotics, inhibit the growth of bacteria by targeting cellular components present in bacteria. Which of the following cellular components is NOT a valid antimicrobial drug target?

- A. Centrosome.
- B. Ribosome.
- C. Cell wall.
- D. RNA polymerase.
- E. DNA polymerase.

5. Which of the following statements concerning the nature of post-transcriptional processing of mRNA is INCORRECT?

- A. The presence of introns is a derived trait of eukaryotes.
- B. Mitochondrial mRNA lacks a 5' cap because capping is a strictly intranuclear process.
- C. Recognition of splice sites by the spliceosome is based on the physical conformation of the mRNA strand, not on any specific consensus sequence.
- D. In some genes, poly-A tails can generate genetic diversity by being added at one of multiple possible sites on the mRNA transcript.
- E. Both 5' caps and poly-A tails inhibit the degradation of the mRNA molecule in the cytosol.

6. Cellular metabolism is bidirectional and complex. Indicate whether the following statements concerning the metabolic capabilities of a nucleated human cell are True or False. *If response A, B, C, or D is TRUE, bubble that response letter on your scantron. If it is FALSE, do NOT bubble the response letter. Each correct response is valued at 0.25 points.*

- A. Can convert sugars to fats True or False
- B. Can convert fats to sugars True or False
- C. Can convert sugars to amino acids True or False
- D. Can convert amino acids to sugars True or False

7. Which of the following is NOT a component of the cell wall or cell membrane?

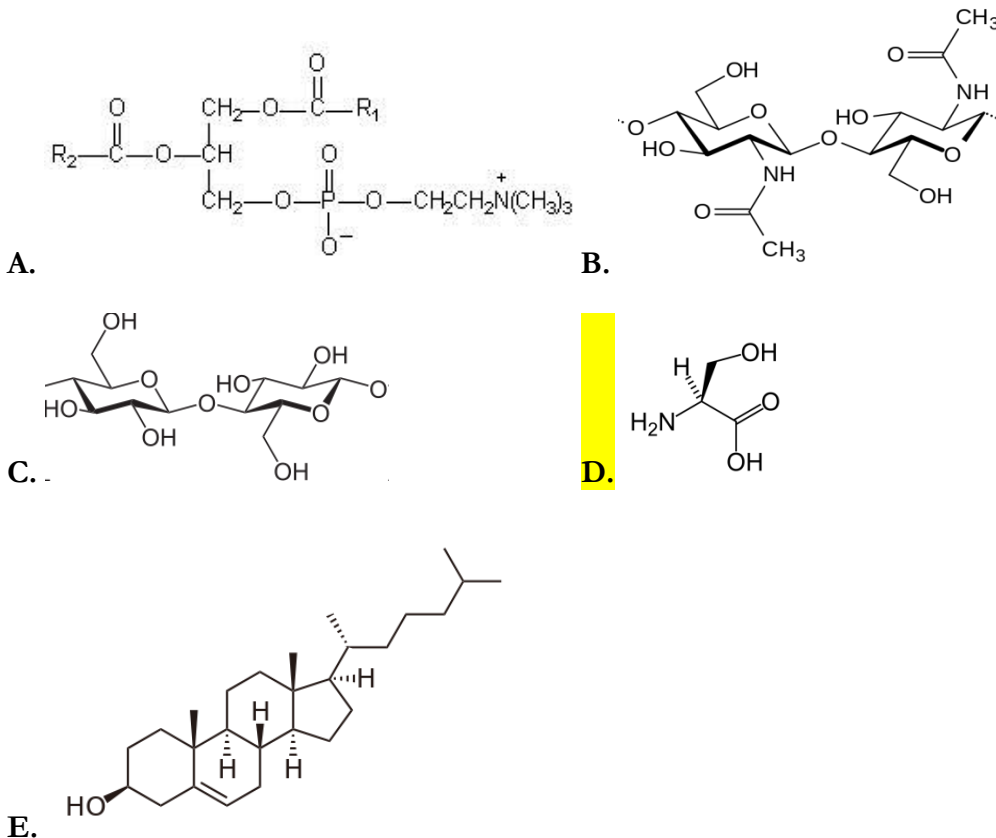

8. Consider the 5' to 3' nature of polymerase and its secondary functions and the structure of a nucleotide and its incorporation into a growing polynucleotide chain. Select the best possible explanation below for why evolution has favored 5' to 3' polymerases, as opposed to 3' to 5' ones.

- A. Binding of a 3' to 5' polymerase to DNA would be impaired.
- B. The polymerase would not be able to conduct proofreading during the replication process.
- C. The active site of such a polymerase would be unable to incorporate the nucleotide substrate.
- D. The polynucleotide chain elongation reaction can only occur in a 5' to 3' manner.
- E. None of the above.

9. Some Archaea have structures called cannulae, which are hollow tubules made of glycoprotein that connect cells. It is thought that the cannulae allow for the exchange of nutrients and communication factors between archaeal cells. If this is so, which is the closest analogue to cannulae from the list below?
- A. Bacterial microtubules.
 - B. Archaeal hami.
 - C. Tight junctions in animal cells.
 - D. Plasmodesmata in plant cells.
 - E. Animal microtubules.
10. Which of the following is not a way for the cell to avoid accumulation of damaged and/or malformed proteins?
- A. Chaperonins.
 - B. Ubiquitination.
 - C. Nucleotide excision repair.
 - D. Proofreading DNA polymerases.
 - E. Dicer.
11. When a cell's DNA is damaged, it may develop into cancer when it divides. Which of the following is most important in preventing development of cancer?"
- A. Cell division cycle (cdc) mutations.
 - B. Hypermutation in the p53 gene.
 - C. Kinetochore selectivity.
 - D. G1/S and G2/M checkpoints.
 - E. M checkpoint.
12. You are walking down Fridhemsgatan in Stockholm, Sweden and you develop a sudden urge for a piece of pizza. You see the Bella Vista Restaurang and go inside and decide to order their specialty the Bella Vista as shown in the picture on the right. As a biology student, you quiz yourself about which ingredient on your pizza as shown in this picture is **NOT** produced by photosynthesis.
- A. Box.
 - B. Oil.
 - C. Mushrooms.
 - D. Onions.
 - E. Sauce.



13. Syngenta Biotechnology introduced Golden Rice 2 to the public in 2005. This rice variety has been genetically engineered to express a higher content of β -carotene. β -carotene is important for vision and is a precursor to which vitamin?

- A. Vitamin A.
- B. Vitamin B.
- C. Vitamin C.
- D. Vitamin D.
- E. Vitamin E.

14. The ABC hypothesis is concerned with flower development. Decide which of the following is True and which is False for a mutant with the C genes knocked out. *If response A, B, C, or D is TRUE, bubble that response letter on your scantron. If it is FALSE, do NOT bubble the response letter. Each correct response is valued at 0.25 points.*

- A. It will have a normal calyx True or False
- B. It will have a normal corolla True or False
- C. It will have a normal gynoecium True or False
- D. It will have a normal androecium True or False

15. You find a wilted houseplant. In addition to the wilting, the plant displays dried-out, yellow streaks on the edges of its leaves. What are the most likely causes of these phenomena?

- A. The plant is over watered. Its cells cannot maintain sufficiently high turgor pressure. In addition, it has a magnesium deficiency.
- B. The plant is over watered. Its cells cannot maintain sufficiently high turgor pressure. In addition, it has a potassium deficiency.
- C. The plant is under watered. Its cells cannot maintain sufficiently high turgor pressure. In addition, it has a potassium deficiency.
- D. The plant is under watered. Its cells cannot maintain sufficiently high turgor pressure. In addition, it has a magnesium deficiency.
- E. The plant is over watered. Its cells cannot maintain sufficiently high turgor pressure. In addition, it has a nitrogen deficiency.

16. Which of the following is NOT true of auxins? They

- A. Seldom stimulate growth.
- B. Are the primary factor responsible for phototropism.
- C. Stimulate root growth.
- D. Delay fruit senescence.
- E. Contribute to the formation and organization of xylem and phloem.

17. The structure in the image on the right is NOT important for which of the following:

- A. Playing an important role of plants movement to land.
- B. Preventing the majority of water loss in the process of transpiration
- C. Providing a major avenue of evaporative loss of water.
- D. Recycling the total water content of the atmosphere.
- E. Regulating CO₂ uptake in photosynthesis.

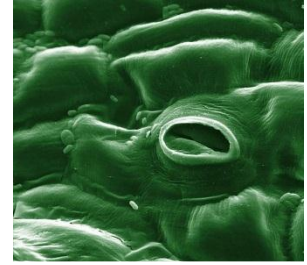

Source: Wikimedia Commons

18. When comparing mitosis in a plant cell to an animal cell, which one of the following summarizes the major differences?

- A. Plant cells do not normally undergo anaphase.
- B. Plant and animal mitosis stages share no differences.
- C. Plant cells spend a longer time in metaphase and anaphase than animal cells.
- D. Animal cells spend longer in metaphase and lack spindle fibers that are present in plant cells.
- E. Plant cells differ in teleophase and do not use centrioles to form the spindle system.

19. You walk outside and are met with a blast of cold resulting from the polar vortex. Your body responds by setting into motion a hormone cascade pathway to activate your thyroid gland. Using the selections below, which of the following is the correct sequence of events for this pathway?

- I. Thyroid Hormone
 - II. TRH
 - III. TSH
-
- A. III, II, I
 - B. III, I, II
 - C. II, III, I
 - D. II, I, III
 - E. I, III, II

20. John is suffering from a *Yersinia pestis* (a pathogenic bacterium) infection. These bacteria have a type III secretion system, involving an injectosome (a proteinaceous syringe) which injects Yop toxins into a certain class of John's cells. The Yop proteins prevent these human cells from performing phagocytosis, from producing toxic (bacteria-killing) forms of oxygen, and from producing cytokines. Which of John's cells are being targeted?
- A. Cytotoxic T cells.
 - B. Dendritic cells.
 - C. Glia Helper
 - D. B cells.
 - E. Macrophages.
21. Diabetes is a condition in which the body either does not produce normal amounts of insulin or does not respond to insulin. Symptoms include elevated blood concentrations of glucose and ketone bodies, including acetone. Ketone bodies are formed during the breakdown of which of the following macromolecules?
- A. Polypeptides.
 - B. Polysaccharides.
 - C. Glycerol.
 - D. Lactose.
 - E. Fatty acids.
22. Indicate whether the following statements about the vertebrate retina are True or False. If response A, B, C, or D is TRUE, bubble that response letter on your scantron. If it is FALSE, do NOT bubble the response letter. Each correct response is valued at 0.25 points.
- A. Rod cells are responsible for black-and-white vision at night, while cone cells are responsible for color vision during the day. True or False
 - B. When a rod cell is exposed to light, its sodium channels close. True or False
 - C. Hyperpolarization of rod cells stimulates release of its neurotransmitters. True or False
 - D. Both rod and cone cells form a direct synaptic connection with the ganglion cells of the optic nerve. True or False
23. You see an advertisement for a test which purports to reveal undiscovered allergic responses by testing your IgG levels. You know that the test is a scam because...
- A. IgGs are involved in localized defense of mucous membranes, and IgEs are involved in the allergic response.
 - B. IgGs are involved in opsonization, neutralization, and crosslinking of antigens, and IgAs are involved in the allergic response.
 - C. IgGs are involved in clonal selection, and IgDs are involved in the allergic response.
 - D. IgGs are involved in opsonization, neutralization, and crosslinking of antigens, and IgEs are involved in the allergic response.
 - E. IgGs are involved in localized defense of mucous membranes, and IgAs are involved in the allergic response.

24. Which of the following ions have higher extracellular concentrations than intracellular concentrations?

- I. Potassium
- II. Sodium
- III. Calcium

- A. I only
- B. II only
- C. I and II
- D. I, II, and III
- E. II and III

25. Select the statement that best describes movement of O_2 , Na^+ , and glucose into and out of the capillaries.

- A. O_2 and glucose diffuse across endothelial cell membranes; Na^+ diffuses through pores between cells.
- B. O_2 and Na^+ diffuse across endothelial cell membranes; glucose diffuses through pores between cells.
- C. O_2 diffuses across endothelial cell membranes; Na^+ and glucose diffuse through pores between cells.
- D. O_2 , Na^+ , and glucose all diffuse across endothelial cell membranes.
- E. O_2 , Na^+ , and glucose all diffuse through pores between endothelial cells.

26. A new chemical is found that inhibits muscle function and in high enough doses causes paralysis. Which of the following is NOT a plausible mechanism by which this chemical could function?

- A. Inhibition of acetylcholinesterase in the synaptic cleft of peripheral motor neurons.
- B. Inhibition of acetylcholine release in peripheral motor neurons.
- C. Inhibition of calcium release in peripheral motor neurons.
- D. Inhibition of the binding of myosin heads to actin filaments in muscle cells.
- E. Inhibition of calcium-release channels in the sarcoplasmic reticulum of muscle cells.

27. The J chain is a linking protein that allows for the IgA and IgM classes of antibodies to be secreted as dimers and pentamers, respectively. A mutant mouse is a knockout for the J chain gene on both chromosomes. What is True and False about its phenotype? *If response A, B, C, or D is TRUE, bubble that response letter on your scantron. If it is FALSE, do NOT bubble the response letter. Each correct response is valued at 0.25 points.*

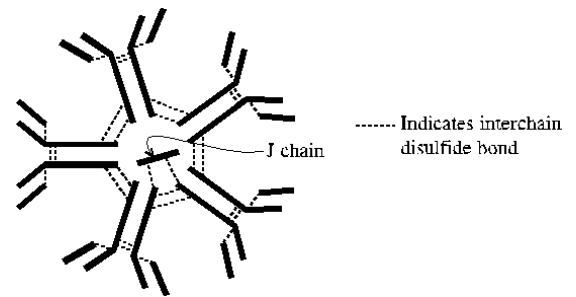

- A. The mouse has no antibodies. True or **False**
 B. The mouse low avidity IgA and IgM. **True** or False
 C. The mouse has normal levels of membrane-bound antibodies (these are B-cell receptors). **True** or False
 D. The mouse has low levels of secreted IgG. True or **False**

Source: <http://www.tulane.edu/~biochem/med/igm.gif>

28. In the 1944 movie *Arsenic and Old Lace*, Mortimer Brewster visits his two aunts and discovers a body in the window seat. Mortimer assumes it is his delusional uncle Teddy who believes he is Theodore Roosevelt, but his aunts immediately respond that it is one of their “responsible charities”. His aunts’ charity is to end the suffering of lonely old bachelors by serving them elderberry wine spiked with arsenic, strychnine, and “just a pinch of cyanide”. Which of the following statements is True and which is False as to how these unfortunate bachelors met their demise? *If response A, B, C, or D is TRUE, bubble that response letter on your scantron. If it is FALSE, do NOT bubble the response letter. Each correct response is valued at 0.25 points.*

- A. Cyanide binds with enzyme cytochrome c oxidase and prevents the cell from aerobically producing ATP. **True** or False
 B. Arsenic disrupts ATP production beginning at the level of the citric acid cycle. **True** or False
 C. Strychnine affects the motor neurons of the spinal cord. **True** or False
 D. Arsenic affects multiple systems in the body. **True** or False

29. Using the following structures, trace the flow of blood entering from the systemic circulation.

- I. Right atrium
- II. Left atrium
- III. Right ventricle
- IV. Left ventricle
- V. Vena cavae
- VI. Aorta
- VII. Pulmonary artery
- VIII. Pulmonary veins

- A. I,II,VII,VIII,III,IV,VI,V.
- B. I,VII,III,XIII,II,IV,VI,V.
- C. V,I,III,VII,VIII,II,IV,VI.
- D. V,I,III,VIII,VII,II,IV,VI.
- E. V,III,I,VII,VIII,IV,II,VI.

30. Which of the following do an ovum and sperm contribute equally?

- A. Cytoplasm.
- B. Mitochondria.
- C. Endoplasmic reticulum.
- D. Nuclear DNA.
- E. Nutrients.

31. Boston is known for having aggressive geese along riverside paths, which frequently stand their ground rather than flee in response to rapidly approaching runners or bikers. City ordinance prohibits causing harm to these geese. At the individual level, what is the most likely explanation for this behavior?

- A. It is innate
- B. It is a consequence of classical conditioning
- C. It is a consequence of operant conditioning
- D. The geese did not observe other geese fleeing during a critical period in development
- E. Runners and bikers do not present sign stimuli

32. When one travels across time zones by airplane, one experiences being tired and disoriented. Decide which statement is true and which is false. Crossing time zones: *If response A, B, C, or D is TRUE, bubble that response letter on your scantron. If it is FALSE, do NOT bubble the response letter. Each correct response is valued at 0.25 points.*
- A. Causes a sudden inconsistency between the internal body clock and the outside world. True or False
 - B. Synchronizes local zeitgebers (external or environmental cues that determine, modify, or synchronize an organism's biological rhythms to the earth's 24-hour light/dark cycle and 12 month cycle). True or False
 - C. West to east does not affect our biological rhythms as much as flying from east to west. True or False
 - D. Increased frequency and severity of piloting errors occur during aircraft operations. True or False
33. The large sea slug, *Aplysia californicus*, has an involuntary gill and siphon withdrawal reflex which causes the siphon and gill to retract when disturbed. Through experimentation, researchers found:
- A. Sensitization was innate but habituation was genetically determined.
 - B. Repeated stimulation exhausted the neurotransmitter being released and caused desensitization.
 - C. Repeated stimulation reduced the amount of the neurotransmitter being released and induced the habituation.
 - D. Repeated stimulation exhausted the neurotransmitter being released and caused the sensitization.
 - E. Shocking the interneurons caused habituation.
34. Black and white mice live on an island and have allele frequencies of $B=0.20$, $b=0.80$. On the continent, there is a much larger population of mice with allele frequencies $B=0.80$, $b=0.20$. Ships begin moving back and forth between the island and the continent. Occasionally, a mouse finds its way onto the ship and leaves the ship and breeds with the mice of the other population. Equal numbers of mice ride in each direction. If the ships move continuously between the island and the continent, will the allele frequencies ultimately stabilize? (Assume that no other forces are affecting allele frequencies.)
- A. Both populations will end up at approximately $B=0.80$, $b=0.20$.
 - B. The island and continent populations will stabilize with an allele frequency of $B=0.50$, $b=0.50$.
 - C. Black mice will move to fixation in both populations, because the B allele is dominant.
 - D. Both populations will end up at $B=0.20$, $b=0.80$.
 - E. The continent's allele frequencies will not change; the island will settle at an equilibrium that is somewhere between the continent's and the island's original states.

35. Chromosome segregation is an important step in both mitosis and meiosis. Determine if the following statements are true or false. *If response A, B, C, or D is TRUE, bubble that response letter on your scantron. If it is FALSE, do NOT bubble the response letter. Each correct response is valued at 0.25 points.*

- A. Abnormalities in sex chromosome segregation in humans are always fatal. True or False
- B. In most mammals and birds, males have XY sex chromosomes. True or False
- C. Down's Syndrome is often caused by a chromosome segregation error. True or False
- D. It is not uncommon for plants to have more than 2 copies of each chromosome. True or False

36. Which of the following is a genetic variation of Klinefelter's Syndrome?

- A. XXX.
- B. XO.
- C. XXO.
- D. XXXO.
- E. XXYY.

37. What is the coefficient of relatedness between individuals A and B?

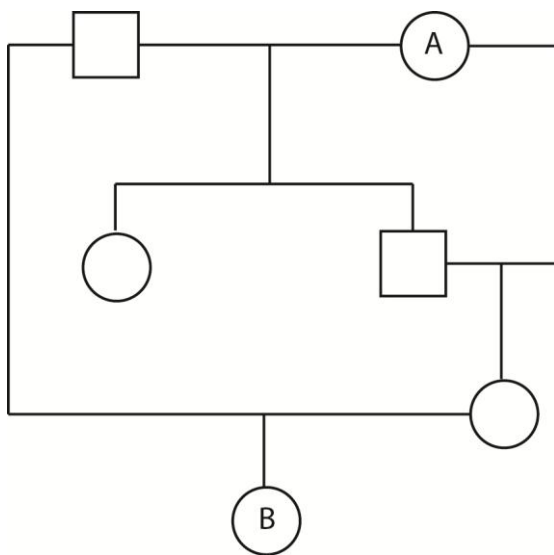

- A. 1/4
- B. 3/8
- C. 1/2
- D. 5/8
- E. 3/4

38. In the mucus of the intestinal epithelium, you observe an interesting relationship between mucus-dwelling bacteria and various bacteriophage. Bacteria continually evolve mechanisms to avoid phage attack, and phage continually evolve methods to get around the bacterial defenses. This is an example of...
- A. Red Queen dynamics.
 - B. Mutualism.
 - C. Convergent evolution.
 - D. Commensalism.
 - E. Ammensalism.
39. A dog breeder wants to breed dogs with thick, shaggy coats. Assume that the thick-coat trait is recessive. Two dogs, both with thick coats and of the same breed, are mated, but all the puppies are short-haired. From this you can conclude that... *If response A, B, C, or D is TRUE, bubble that response letter on your scantron. If it is FALSE, do NOT bubble the response letter. Each correct response is valued at 0.25 points.*
- A. Having two copies of the thick coat allele is lethal. True or False
 - B. There is another gene controlling the expression of the thick-coat genes by epistasis. True or False
 - C. Dogs of this breed with thick coats are never true breeding for the thick coat trait. True or False
 - D. There are two thick-coat genes at separate loci; each parent is double recessive for a different one, and the genes complement each other in the puppies. True or False
40. A pea plant X dihybrid for flower color and height is crossed with a pea plant Y true breeding for flower color and height. Pea plant X is tall and has purple flowers while pea plant Y is short and has white flowers. Given that the genes are on separate chromosomes, tall is dominant to short and purple is dominant to white, find the phenotypic ratios of the offspring.
- A. 1 tall purple: 1 short purple: 1 tall white: 1 short white.
 - B. 9 tall purple: 3 short purple: 3 tall white: 1 short white.
 - C. 9 tall purple: 3 short purple: 4 short white.
 - D. 9 tall purple: 7 short white.
 - E. 9 tall purple: 4 short white.

41. Which of the following statements apply to viral capsids? *If response A, B, C, or D is TRUE, bubble that response letter on your scantron. If it is FALSE, do NOT bubble the response letter. Each correct response is valued at 0.25 points.*

- A. Viral capsomeres display self-assembly and depending on the virus can form helical or icosahedral capsids. **True** or False
- B. Each viral capsid is formed from identical capsomeres, which allows for self-assembly. True or **False**
- C. Viral capsomeres are derived from host proteins and undergo virus-specific post-translational modifications True or **False**
- D. Viral mRNA transcripts are translated by eukaryotic ribosomes to form capsid proteins. **True** or False

42. In 1904, soon after Mendel's work was rediscovered, the French biologist Lucien Cuenot performed experiments with mice that did not appear to follow Mendel's laws. He found that when two yellow-colored mice were crossed, litters with both yellow- and gray-colored offspring were always produced. Over the years, he collected the following data.

Yellow x Yellow → 263 yellow-colored mice and 100 gray-colored mice.

In 1910, W.E. Castle confirmed Cuenot's results with similar experiments. Their combined data are shown in the table below.

	Yellow	Gray	Total	% Yellow
Cuenot	263	100	363	72.45
Castle	800	435	1235	64.77
Total	1063	535	1598	66.52

Which of the following is the most likely explanation for yellow and gray coat colors in the mice?

- A. Gray color is caused by a homozygous recessive condition in either or both of two separate genes that are interacting epistatically.
- B. Gray color is homozygous recessive, and yellow color can either be homozygous or heterozygous.
- C. Gray color is homozygous, yellow color is heterozygous, and the yellow allele is lethal when homozygous.**
- D. Yellow color is caused by the recessive allele of a X-linked gene.
- E. There are fewer gray-colored mice than expected due to double-crossover.

43. If a yellow-coat colored mouse is crossed with a gray-coat colored mouse, what phenotypic frequency is expected among their progeny?
- A. 1/2 yellow, 1/2 gray
 - B. 3/4 gray, 1/4 yellow
 - C. 3/4 yellow, 1/4 gray
 - D. 7/16 gray, 9/16 yellow
 - E. 9/16 yellow, 7/16 gray
44. Although babies have been switched at birth it is a rare occurrence. One case involved a baby whose mother had O, N, RH⁺ blood and whose father had A, MN, Rh⁻ blood. Which child below most likely belongs to this couple?
- A. AB, MN, Rh⁺.
 - B. B, N, Rh⁻.
 - C. A, M, Rh⁺.
 - D. AB, M, Rh⁻.
 - E. O, N, Rh⁺.
45. A population of iguanas with varying degrees of pigmentation inhabits an island. A newly introduced predator is better able to hunt lightly pigmented iguanas, allowing darker iguanas to breed more successfully. The population will exhibit the effects of:
- A. Balancing Selection.
 - B. Disruptive selection.
 - C. Gene flow.
 - D. Directional selection.
 - E. Multifactorial traits.
46. In a particular ecosystem, the biomass pyramid looks like this:

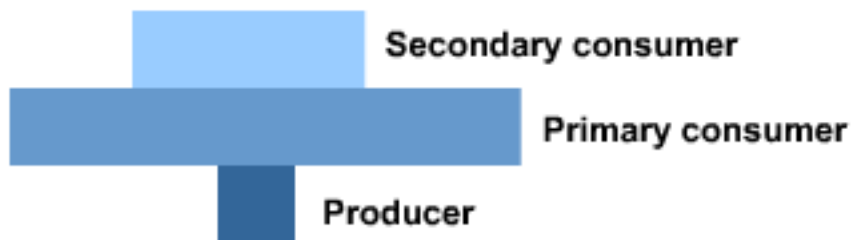

Indicate whether the following statements about this ecosystem are true and which are false. If response A, B, C, or D is TRUE, bubble that response letter on your scantron. If it is FALSE, do NOT bubble the response letter. Each correct response is valued at 0.25 points.

- A. The turnover time of the producers is especially fast. True or False
- B. The producers are especially poor at converting sunlight to biomass. True or False
- C. The primary consumers must have an especially high ecological efficiency. True or False
- D. This type of pyramid can be observed in a stable ecosystem. True or False

47. In the graph below, which point indicates where populations should be harvested to best obtain optimal yield?

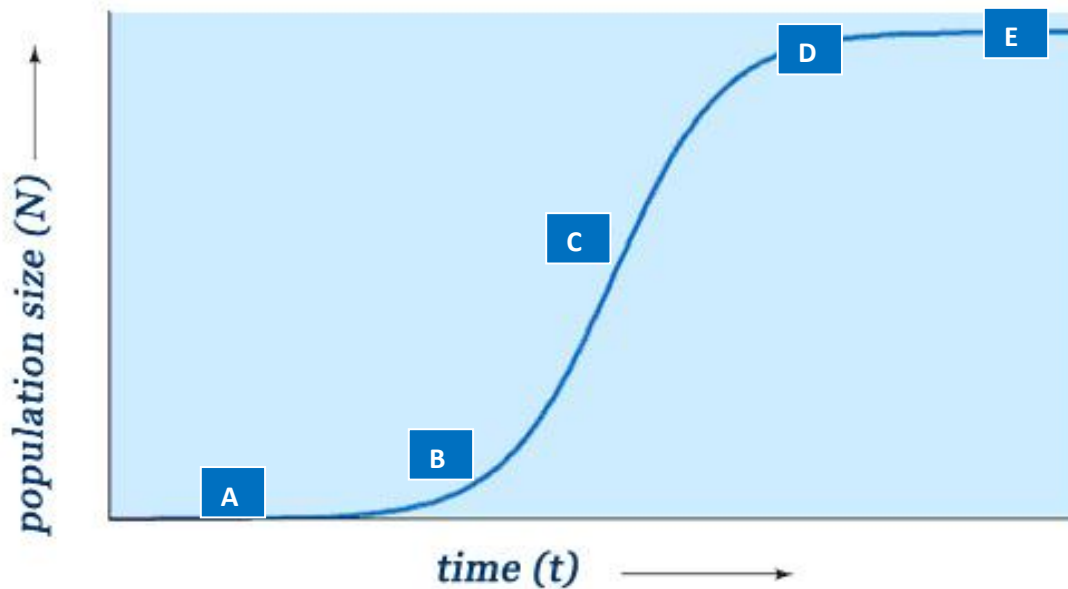

C

48. Which of the following biomes receives the most annual rainfall?

- A. Savannah.
- B. Chaparral.
- C. Temperate broadleaf.
- D. Desert.
- E. Tundra.

49. Which of the following plants does NOT have leaves that could be classified as an example of an evolutionary adaptation?

- A. *Allium*
- B. *Ananas*
- C. *Opuntia*
- D. *Pisum*
- E. *Ranunculus*

50. Which of the following is a true statement about the life cycles of seedless plants?

- A. In charophycean algae (*Charales*), the sporophyte generation is dominant.
- B. In mosses (*Bryophyta*), the gametophyte generation is dominant.
- C. In liverworts (*Marchantiopsida*), the dominant generation is diploid.
- D. In club mosses (*Lycopodiopsida*), the dominant generation is haploid.
- E. In ferns (*Polypodiopsida*), the haploid generation is reduced to a single cell.