

Allocation Point Max: 100

Q, Point, Mark, Answer

Q1, 3, [No. 1] 7

Q2, 2, [No.2]1, [No.3]5, [No.4]6,

Q2, 2, [No.5]2, [No.6]1, [No.7]2,

Q3, 2, [No.8] 3

Q4, 4, [No.9] 6

Q5, 4, [No. 10]. 3

Q6, 2, [No. 11]. 1

Q6, 2, [No. 12]. 1

Q6, 2, [No. 13]. 1

Q6, 2, [No. 14]. 1

Q7, 2, [No. 15]0, [No. 16]4, [No. 17]0

Q8, 4, [No. 18] 6

Q9, 5, [No. 19] 5

Q10, 4, [No. 20] 5 or 9

Q10, 4, [No. 21] 5 or 9

Q11, 2, [No. 22] 5

Q12, 4, [No. 23] 5

Q13, 6, [No. 24] 6

Q14, 4, [No. 25] 7

Q15, 6, [No. 26] 3

Q16, 3, [No.27] 1

Q16, 3, [No.28] 3

Q16, 1, [No.29] 3

Q16, 1, [No.30] 2

Q16, 1, [No.31] 1

Q16, 1, [No.32] 3

Q16, 3, [No.33] 3

Q17, 4, [No. 34] 0 [No. 35] 0 [No. 36] 0 [No. 37] 2 [No. 38] 8

Q18, 8, [No. 39] 0 [No. 40] 1 [No. 41] 0 [No. 42] 4 [No. 43] 9

Q18, 2, [No.44] 2

Q19, 1~ 7, [No.45] _ [No. 46][No. 47][No. 48][No. 49][No. 50]

Allocation List for the No.45-50

7 6_05949 55

6 6_03096 53

5 6_07216 35

5 6_01901 28
5 6_02988 23
4 6_02005 19
4 6_05957 17
4 6_04413 14
3 6_02079 8
3 6_05154 7
3 6_05449 6
3 6_05205 5
3 6_04415 5
3 6_03786 5
2 6_03270 3
2 6_04254 2
1 6_08973 1
1 6_07753 1
1 6_06779 1
1 6_05312 1
1 6_01881 1

Answer key of practical exam animal physiology

Part 1

Q1

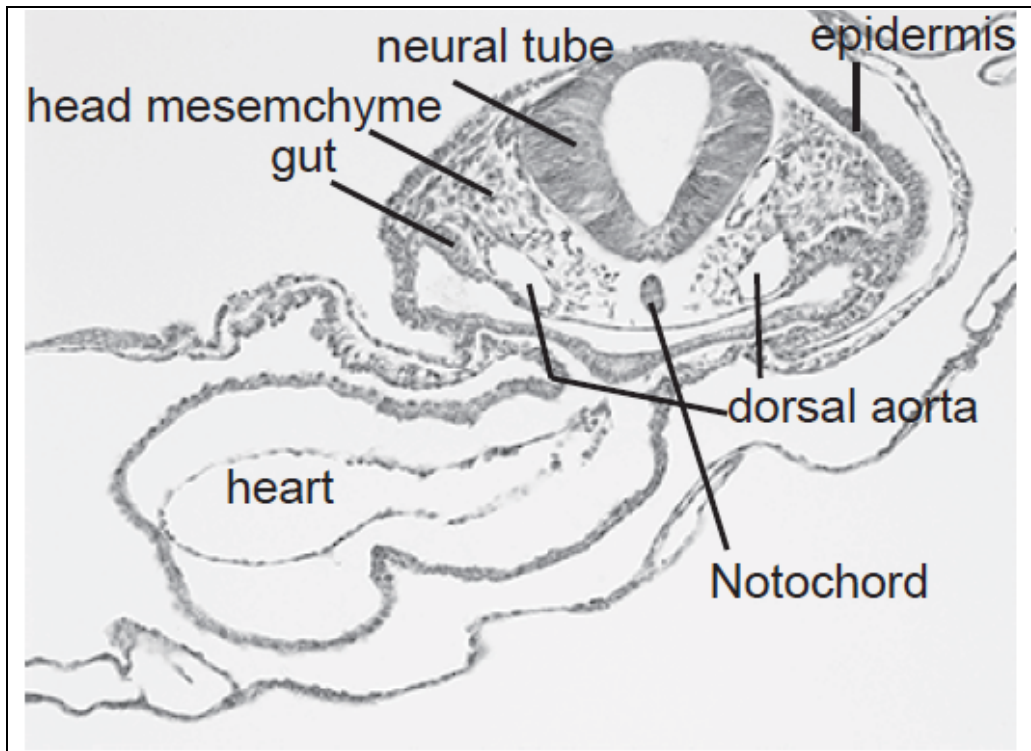

Names of embryonic tissues in the figure are for understanding following grading criteria. Students do NOT need to identify any of them.

Grading criteria

1. The neural tube, epidermis, the gut tube, the notochord, a pair of dorsal aorta, head mesenchyme, and the heart are properly arranged in the drawing. (0-7 points)
2. Cells in the neural tube, epidermis, and the gut tube are shown densely arranged as epithelial structures and the difference of thickness are correctly shown. (0-6 points)
3. Cells in head mesenchyme are distributed loosely compared with those in the neural tube. (0-3 points)
4. Cells in the heart and dorsal aorta are drawn as thin epithelium. (0-4 points)

Q2

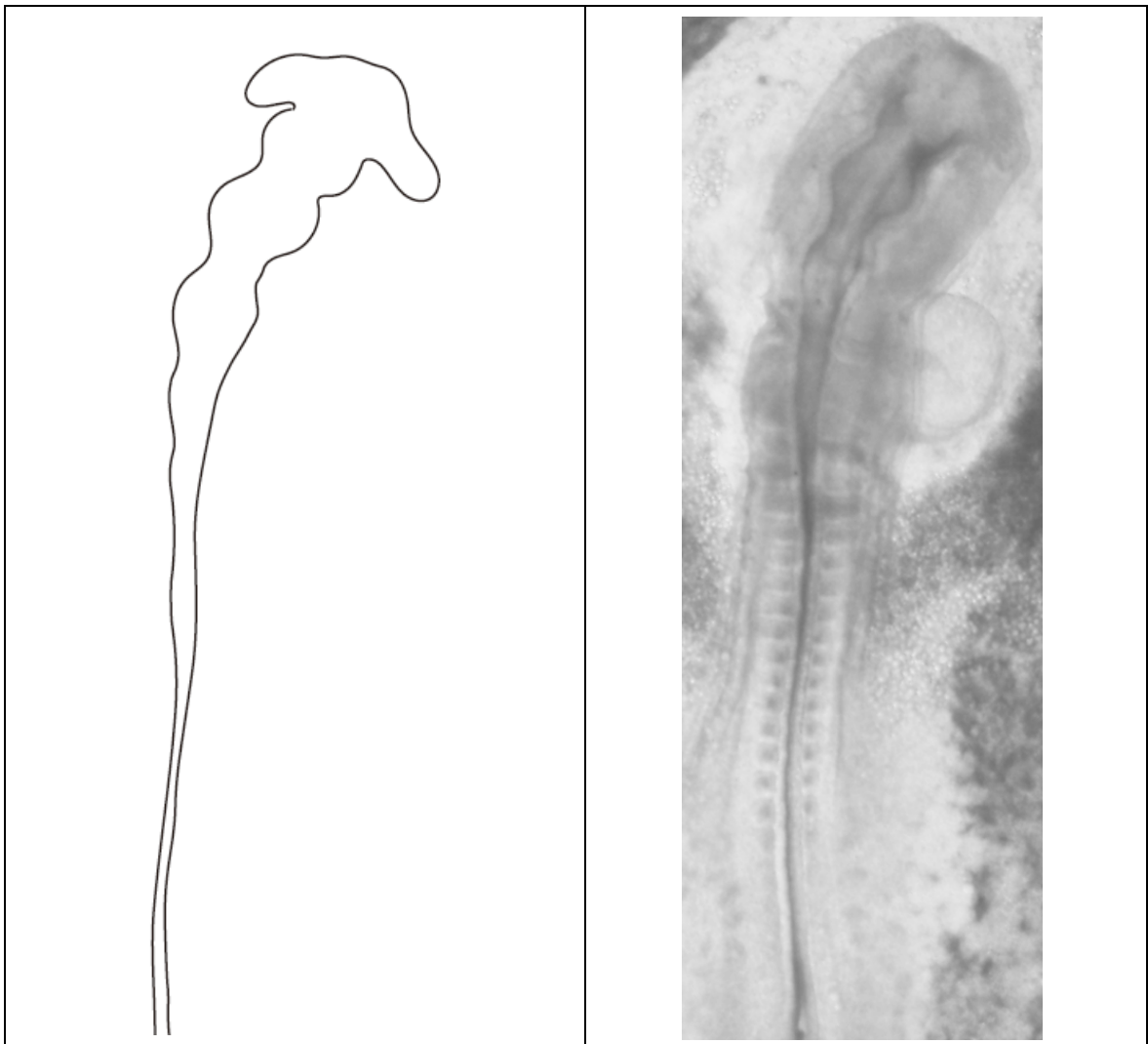

Note

Regardless of aspect ratio in drawing.

Posterior end doesn't have to be drawn clearly.

Grading criteria

The neural tube is a simple tube extending anterior-posteriorly. (0-2 points)

Anterior neural tube is larger than posterior. (0-3 points)

Anterior neural tube can be divided into 4 parts. (0-4 points)

A pair of diverticula, optic vesicles protrude from the most anterior chamber bilaterally. (0-4 points)

The left optic vesicle is anterior than right one. (0-2 points)

Page 2

signature

Q3

A	B	C	D
1	5	9	8

Q4

4-1

4-1-1	4-1-2
c	a

4-2

a

4-3

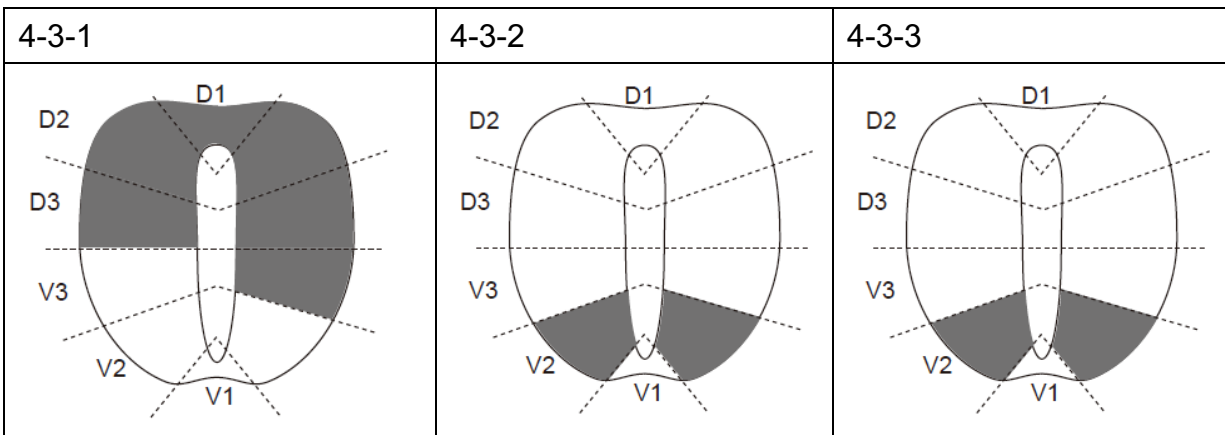

Note

4-3-2 and 4-3-3 should be symmetry.

4-3-2 : P2 should be expressed as same as the right side of photo 6C (the middle of V2) on both side of the neural tube.

4-3-3 : P3 should be expressed as same as the left side of photo 6C (almost whole V2) on both side of the neural tube.

Q5

5-1

d, f, g

5-2

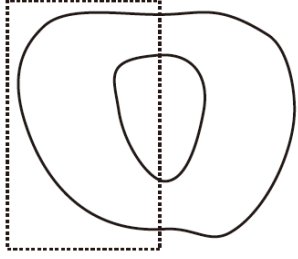
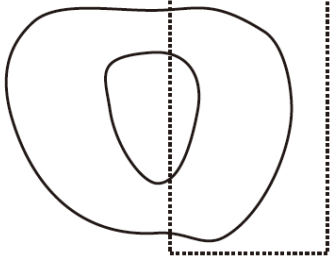
A1			A2		
A3	a	79	A4	a	83
	b	23		b	36
	c			c	
A5	b/a				
A6	0.29		A7	0.43	

Note:

The region for analysis can be different.

In counting number (A3 and A4), 5% (in a)-10% (in b) difference will be accepted.

In the last value (A6 and A7), difference of number of digits and rounding mistake is allowed.

a/b in A5 and values of A6 and A7 based on the formula will be given 13 points (full mark is 15 points).

Alternative acceptable answer is counting b and c and formula is $b/(b+c)$.

Part 2

Q1

1-1:

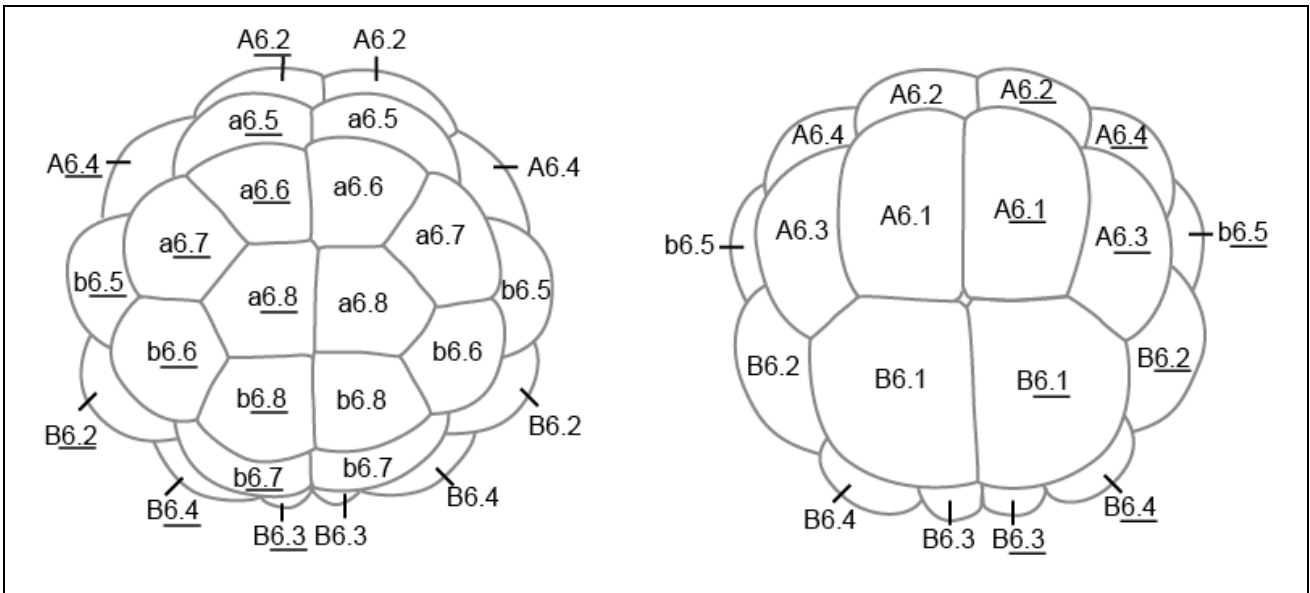

A6.1, A6.3, A6.2, A6.4, A6.1, A6.3, A6.2, A6.4

a6.5, a6.6, a6.7, a6.8, b6.5, b6.6, b6.7, b6.8, a6.5, a6.6, a6.7, a6.8, b6.5, b6.6, b6.7, b6.8

Grading criteria

1. Accurately identify the number of cells that express the gene W in the animal (a- and b- cells) and vegetal hemispheres (A- and B- cells). (5 points)
2. Accurately identify the anterior and posterior axis in the vegetal hemisphere. (5 points)
3. Accurately identify the anterior and posterior axis in the animal hemisphere. (5 points)

Q2

2-1:

A1	A2	A3	A4	A5
A6.4	A6.1 <u>A6.1</u>			

There is an additional explanation in p. 7.

2-2:

b, c

2-3:

1

A1	A2	A3	A4
b	c	b	e

2

A1	A2	A3	A4
a	d	b	c

3

A1	A2	A3	A4
b	b	a	i

The order of experiments is irrelevant.

There is an additional explanation in p. 8.

Additional explanation for Part2 Q2 2-1

Experiment 1: The daughter cells of A6.2 cells did not express gene Y when the embryo was treated with an inhibitor of the receptor for secreted factor X.

X is required.

Experiment 2: The daughter cells of A6.2 did not express gene Y when A6.2 cells were isolated from the embryo and cultured in isolation.

X from cells other than A6.2 is required.

Experiment 3: Four A6.2 cells were collected from four 32-cell stage embryos and cultured together. The cells were in contact with each other during culture. Daughter cells of A6.2s did not express gene Y. The results were the same when the number of A6.2 cells that were cultured in contact was increased.

X from cells other than A6.2 is required.

Experiment 4: The daughter cells of A6.2 expressed gene Y when the expression of gene X was suppressed in either A6.1, A6.1, A6.3, or A6.4 cells.

X from three cells among A6.1, A6.1 A6.3 and A6.4 is sufficient.

Experiment 5: The daughter cells of A6.2 did not express gene Y when the expression of gene X was suppressed in both A6.1 and A6.4 cells. The results were the same when the expression of gene X was suppressed in both A6.1 and A6.4 cells.

X from [A6.1 AND A6.3] is not sufficient.

X from [A6.1 AND A6.3] is not sufficient.

This also means that X from single cells [A6.1 or A6.1 or A6.3] is not sufficient.

Experiment 6: The daughter cells of A6.2 expressed gene Y when the expression of gene X was suppressed in both A6.1 and A6.3 cells. The results were the same when the expression of gene X was suppressed in both A6.1 and A6.3 cells.

X from [A6.1 AND A6.4] is sufficient.

X from [A6.1 AND A6.4] is sufficient.

There are two possibilities which are NOT denied by these experiments.

1. X from single cells [A6.4] can induce Y expression in A6.2.

X from combination of A6.4 with other cells [A6.1 or A6.1 or A6.3] is also sufficient, but it is NOT the smallest combination.

2. X from two cells [A6.1 AND A6.1] can induce Y expression in A6.2.

Additional explanation for Part2 Q2-2

To prove X from either [A6.1, A6.1(R), A6.3, and A6.4.] and Z in A6.2 independently and cooperatively regulate Y gene in A6.2, you have to prove three hypotheses as following:

1. X does not affect the expression of Z. (i.e. X is not required for Z expression.)
2. Z does not affect the expression of X. (i.e. Z is not required for X expression.)
3. Cells that receive X and express Z can express Y. (i.e. [X AND Z] are sufficient for Y expression.)

Answer key 2 experiments proves hypothesis 2. adbc

When Z was inhibited in A6.2, expression of X in A6.1, A6.1(R), A6.3, and A6.4. should not change (i.e. not decrease).

Answer key 3 experiments proves hypothesis 1. bbai

When X was inhibited in in A6.1, A6.1(R), A6.3, and A6.4, expression of Z in A6.2. should not change (i.e. not decrease).

Answer key 1 experiments proves hypothesis 3. bcbe

A6.1, A6.1, A6.3 and A6.4 secrete X (therefore, cells may receive X). Ectopic expression of Z in these cells will create cells that receive X and express Z. So, if Y is expressed in A6.1, A6.1, A6.3 or A6.4, Z and X regulate gene Y expression cooperatively.

Some may think overexpression experiments can also prove hypotheses 1 and 2 as below.

A1. Overexpression of Z in A6.2 doesn't affect (i.e. not increase) expression of X in A6.1, A6.1(R), A6.3, and A6.4.

A2. Overexpression of X in A6.1, A6.1(R), A6.3, and A6.4. doesn't affect (i.e. not increase) expression of Z in A6.2.

These seem logically correct, but in biology these experiments are NOT suitable for prove epistasis.

As is often the case with chemical reagent and enzyme reactions, a reaction may be seen in one concentration range but not at higher concentrations.

In the case of A1, even if X is under the control of Z, overexpression of Z may not increase X because concentration of Z by overexpression in addition of its endogenous expression is out of the reactive concentration to affect X expression. From overexpression experiments, it may be difficult to see the relationship between X and Z unless the concentration range is carefully examined. Therefore, biological studies generally rely on functional inhibition rather than overexpression.

Although these thinking is common among biological researchers, we will give these two experiments, acbc and baai combination, partial mark (3 out of 5 points) because they are logically possible.